

Hydro Unit M 018T - 030T

Monobloc heat pumps

Version . 1.0

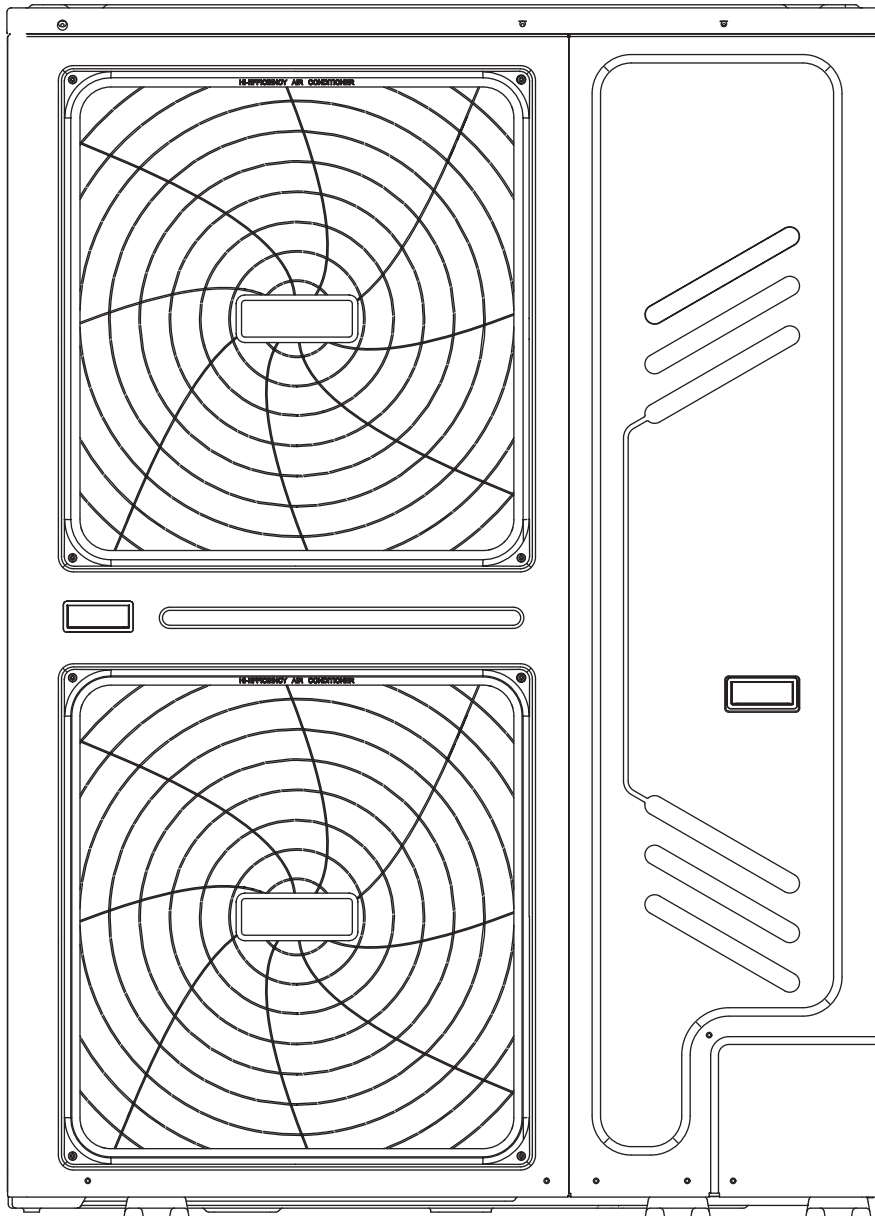

Contents

Product description	4
Technical data	5
Dimensions and layouts	13
Control panel	21
Specifications guide	22

Product description

Hydro Unit M 018T - 030T

Hydro Unit M is the ideal concept for all kinds of residential and commercial heating and cooling application - and can also produce energy-efficient domestic hot water.

The unit works with R32 ecological refrigerant, guaranteeing not only low global warming potential (GWP) and low CO₂ emissions, but also optimum energy efficiency over the whole operating range.

Hydro Unit M is also fitted with new exchange coils with the special hydrophilic and anti-corrosion Blue-Fin treatment that improves the drainage of condensate on the fins, thereby reducing the risk of the coils freezing (maximum efficiency even in damp climates).

The monobloc unit means that all components are housed inside it to facilitate and speed up installation operations.

Hydro Unit M is supplied with climate control as standard and is available in 4 models from 18 to 30 kW.

- Twin rotary compressor with DC inverter technology, that modulates the output to adapt perfectly to the real load needed.
- High COP and EER values (all Hydro Unit M heat pumps comply with the highest standards requested in terms of energy efficiency).
- Performance ratings certified by the third party body HP Keymark.
- They can be connected to low-temperature radiators, radiant floor elements and fan coil type units.
- Water heating temperature up to +60°C.
- Easy, quick installation.
- Low unit noise level.
- Wired control panel included, for the complete management of a heating/cooling/DHW system.
- The control panel can manage up to 6 units (even of different output levels) in cascade format - 1 master and 5 slaves.
- Anti-freeze protection as standard, to protect the entire system - in particular the hydraulic parts - from the potential damage caused by freezing.



Technical data

Description	Unit	Hydro Unit M			
		018T	022T	026T	030T
PERFORMANCE DATA IN HEATING					
Performance in heating (A7°C; W35°C)					
Nominal capacity	kW	18,00	22,00	26,00	30,10
Input power	kW	3,83	5,00	6,37	7,70
COP		4.70	4.40	4,08	3,91
SCOP (temperate zone)		4,6	4,53	4,5	4,19
Seasonal energy efficiency	%	181	178	177	165
Energy class		A+++	A+++	A+++	A++
Performance in heating (A7°C; W45°C)					
Nominal capacity	kW	18,00	22,00	26,00	30,00
Input power	kW	5,14	6,47	8,39	10,34
COP		3.50	3.40	3.10	2.90
Performance in heating (A7°C; W55°C)					
Nominal capacity	kW	18,00	22,00	26,00	30,00
Input power	kW	6,55	8.30	10,61	13,04
COP		2.75	2,65	2,45	2.30
SCOP (temperate zone)		3,21	3,22	3,14	3,14
Seasonal energy efficiency	%	125	126	123	123
Energy class		A++	A++	A+	A+
PERFORMANCE DATA IN COOLING					
Performance in cooling (A35°C; W7°C)					
Nominal capacity	kW	17,00	21,00	26,00	29,50
Input power	kW	5,57	7,12	9,63	11,57
EER		3,05	2.95	2.70	2.55
SEER		4.70	4.70	4,66	4,49
Seasonal energy efficiency	%	185	185	183	177
Performance in cooling (A35°C; W18°C)					
Nominal capacity	kW	18,50	23,00	27,00	31,00
Input power	kW	3.89	5,00	6,28	7,75
EER		4.75	4.60	4,30	4.00
ELECTRICAL CHARACTERISTICS					
Electrical supply	V/ph/Hz	400/3/50	400/3/50	400/3/50	400/3/50
Total maximum input power (1)	kW	10,60	12.50	13.80	14,50
Total maximum input current (2)	A	16,80	19,60	21,60	22,80
COMPRESSOR					
Compressor	Type/brand	Twin Rotary/ Mitsubishi	Twin Rotary/ Mitsubishi	Twin Rotary/ Mitsubishi	Twin Rotary/ Mitsubishi
Adjustment	Type	Inverter modulating	Inverter modulating	Inverter modulating	Inverter modulating
Minimum capacity control	%	24	24	24	24
Refrigerant	Type	R32	R32	R32	R32
GWP	CO ₂ equiv. in t/kg	675	675	675	675
Refrigerant load	kg	5.00	5.00	5.00	5.00
Control box load	CO ₂ equiv. in t	3,38	3,38	3,38	3,38
Number of circuits	no.	1	1	1	1
Hermetically sealed control box (EU reg. 517_2014)	yes/no	yes	yes	yes	yes

Product description

Description	Unit	Hydro Unit M			
		018T	022T	026T	030T
FAN					
Fan	Type	Axial	Axial	Axial	Axial
Quantity	no.	2	2	2	2
Maximum air flow rate	m ³ /h	10650	10650	11200	11200
HEAT EXCHANGER (SOURCE SIDE)					
Heat exchanger (source side)	Type	Pipes in copper with grooves, fins in hydrophilic aluminium and anti-corrosion finishing	Pipes in copper with grooves, fins in hydrophilic aluminium and anti-corrosion finishing	Pipes in copper with grooves, fins in hydrophilic aluminium and anti-corrosion finishing	Pipes in copper with grooves, fins in hydrophilic aluminium and anti-corrosion finishing
CIRCULATION PUMP					
Circulation pump	Type	3-speed centrifuge	3-speed centrifuge	3-speed centrifuge	3-speed centrifuge
Nominal delivery	m ³ /h	3.10	3,79	4.48	5,19
Maximum operating pressure	bar	3	3	3	3
Maximum input power	kW	0,262	0,262	0,262	0,262
Maximum input current	A	1.20	1.20	1.20	1.20
Expansion tank volume	l	8.00	8.00	8.00	8.00
HEAT EXCHANGER (SYSTEM SIDE)					
Heat exchanger (system side)	Type	AISI316 stainless steel plate	AISI316 stainless steel plate	AISI316 stainless steel plate	AISI316 stainless steel plate
Water content	l	3.5	3.5	3.5	3.5
SOUND DATA					
Sound output (3)	dB(A)	71	73	75	77
Sound pressure at 1m (4)	dB(A)	57,6	59.8	61.5	63.5
WEIGHT					
Net weight	kg	177	177	177	177

The performance values comply with UNI EN:14511 and UNI EN 14825 standards. Performance data certified by HP Keymark.

- (1) Input power from compressors and from fans and circulator in the maximum operating conditions, with the nominal power supply voltage.
- (2) Maximum unit operating current with the nominal power supply voltage.
- (3) Sound emission values declared, in accordance with standard EN 12102-1.
- (4) Measured in a semi-anechoic chamber, at a distance of 1m from the front of the unit and a height from the floor equal to $(1+H)/2$, where H is the height of the unit expressed in metres (in accordance with standard EN 12102-1).

Product description

ERP regulation technical data table

Parameter	Unit	Hydro Unit M			
		018T	022T	026T	030T
Temperate zone - Low temperature (30/35°C) EU reg. 811_2013					
Seasonal energy efficiency	%	181	178	177	165
SCOP		4,60	4,53	4,50	4,19
Prated	kW	17,99	22,31	25,04	29,18
Energy class		A+++	A+++	A+++	A++
Sound output	dB(A)	71	73	75	77
Temperate zone - Medium temperature (47/55°C) EU reg. 811_2013					
Seasonal energy efficiency	%	125	126	123	123
SCOP		3,21	3,22	3,14	3,14
Prated	kW	17,67	22,43	26,15	29,69
Energy class		A++	A++	A+	A+

The performance values comply with UNI EN:14511 and UNI EN 14825 standards.

Product description

PERFORMANCE IN ACCORDANCE WITH EN 14511 and EN 14825 STANDARDS

HYDRO UNIT M 018T - HEATING

Delivery temperature	Performance with full load					
	35°C		45°C		55°C	
Outdoor temperature	Nominal capacity (kW)	COP	Nominal capacity (kW)	COP	Nominal capacity (kW)	COP
-7	19,91	2,37	16,16	1,98	10,08	1,18
2	20,23	3,16	19,97	2,64	17,74	2,15
7	18,00	4,70	18,00	3,50	18,00	2,75
12	21,22	4,17	19,34	3,60	18,57	2,90
15	22,08	4,32	20,89	3,89	19,18	3,22
20	23,78	4,46	21,28	4,08	20,38	3,44
35	12,48	6,58	11,91	5,24	11,13	3,81
Performance with partial load						
Tbival (-7°C)	A	B	C	D	-	-
Outdoor temperature (°C)	-7	2	7	12	-	-
PLR - Climate load factor	0,88	0,54	0,35	0,15	-	-
DC - Output with full load	19,91	20,23	18,00	21,22	-	-
COP with full load	2,37	3,16	4,70	4,17	-	-
COP with partial load	2,79	3,96	4,39	3,69	-	-
CR - Load factor	1,00	0,48	0,35	0,13	-	-
f COP - Corrective factor	1,00	1,25	0,93	0,88	-	-

NOTE: the performance values with a partial load refer to an output water temperature of 35°C.

HYDRO UNIT M 018T - COOLING

	Load factor	Outdoor temperature (°C)	EER
EER1	100%	35	3,05
EER2	75%	30	4,13
EER3	50%	25	5,59
EER4	25%	20	5,55

HYDRO UNIT M 022T - HEATING

Delivery temperature	Performance with full load					
	35°C		45°C		55°C	
Outdoor temperature	Nominal capacity (kW)	COP	Nominal capacity (kW)	COP	Nominal capacity (kW)	COP
-7	21,28	2,44	19,82	2,03	12,55	1,25
2	23,24	3,02	23,02	2,51	21,04	2,12
7	22,00	4,40	22,00	3,40	22,00	2,65
12	25,95	3,99	24,15	3,37	22,99	2,822
15	28,05	4,13	26,31	3,56	24,59	3,11
20	27,75	4,33	25,97	3,77	23,95	3,30
35	12,46	6,48	11,88	5,17	11,20	3,81
Performance with partial load						
Tbival (-7°C)	A	B	C	D	-	-
Outdoor temperature (°C)	-7	2	7	12	-	-
PLR - Climate load factor	0,88	0,54	0,35	0,15	-	-
DC - Output with full load	21,28	23,24	22,00	25,95	-	-
COP with full load	2,44	3,02	4,40	3,99	-	-
COP with partial load	2,68	3,80	4,61	3,81	-	-
CR - Load factor	1,00	0,52	0,35	0,13	-	-
f COP - Corrective factor	1,10	1,26	1,05	0,95	-	-

NOTE: the performance values with a partial load refer to an output water temperature of 35°C.

HYDRO UNIT M 022T - COOLING

	Load factor	Outdoor temperature (°C)	EER
EER1	100%	35	2,95
EER2	75%	30	3,95
EER3	50%	25	5,37
EER4	25%	20	6,19

Product description

HYDRO UNIT M 026T - HEATING

Delivery temperature	Performance with full load					
	35°C		45°C		55°C	
Outdoor temperature	Nominal capacity (kW)	COP	Nominal capacity (kW)	COP	Nominal capacity (kW)	COP
-7	23,46	2,52	21,45	2,08	15,28	1,31
2	25,44	2,90	26,17	2,40	23,10	2,09
7	26,00	4,08	26,00	3,10	26,00	2,45
12	29,34	3,82	28,67	3,17	26,05	2,75
15	30,79	3,95	30,62	3,30	26,56	3,00
20	32,48	4,21	30,13	3,53	26,78	3,18
35	12,43	6,38	11,85	5,10	11,26	3,81
Performance with partial load						
Tbival (-7°C)	A	B	C	D	-	-
Outdoor temperature (°C)	-7	2	7	12	-	-
PLR - Climate load factor	0,88	0,54	0,35	0,15	-	-
DC - Output with full load	23,46	25,44	26,00	29,34	-	-
COP with full load	2,52	2,90	4,08	3,82	-	-
COP with partial load	2,52	3,83	4,78	3,98	-	-
CR - Load factor	1,00	0,53	0,34	0,13	-	-
f COP - Corrective factor	1,00	1,32	1,17	1,04	-	-

NOTE: the performance values with a partial load refer to an output water temperature of 35°C.

HYDRO UNIT M 026T - COOLING

	Load factor	Outdoor temperature (°C)	EER
EER1	100%	35	2,70
EER2	75%	30	3,79
EER3	50%	25	5,19
EER4	25%	20	6,84

HYDRO UNIT M 030T - HEATING

Delivery temperature	Performance with full load					
	35°C		45°C		55°C	
Outdoor temperature	Nominal capacity (kW)	COP	Nominal capacity (kW)	COP	Nominal capacity (kW)	COP
-7	24,85	2,54	25,43	2,13	19,93	1,56
2	26,02	2,86	28,19	2,29	24,65	1,97
7	30,10	3,91	30,00	2,90	30,00	2,30
12	31,14	3,67	33,35	3,01	31,14	2,68
15	32,70	3,79	36,01	3,09	32,59	2,90
20	32,70	4,08	35,34	3,33	32,48	3,06
35	12,41	6,29	11,82	5,03	11,33	3,80
Performance with partial load						
Tbival (-7°C)	A	B	C	D	-	-
Outdoor temperature (°C)	-7	2	7	12	-	-
PLR - Climate load factor	0,88	0,54	0,35	0,15	-	-
DC - Output with full load	24,85	26,02	30,10	31,14	-	-
COP with full load	2,54	2,86	3,91	3,67	-	-
COP with partial load	2,49	3,59	4,68	4,18	-	-
CR - Load factor	1,00	0,61	0,34	0,14	-	-
f COP - Corrective factor	1,00	1,25	1,20	1,14	-	-

NOTE: the performance values with a partial load refer to an output water temperature of 35°C.

HYDRO UNIT M 030T - COOLING

	Load factor	Outdoor temperature (°C)	EER
EER1	100%	35	2,55
EER2	75%	30	3,62
EER3	50%	25	5,06
EER4	25%	20	6,75

Product description

Operating limits

COOLING MODE

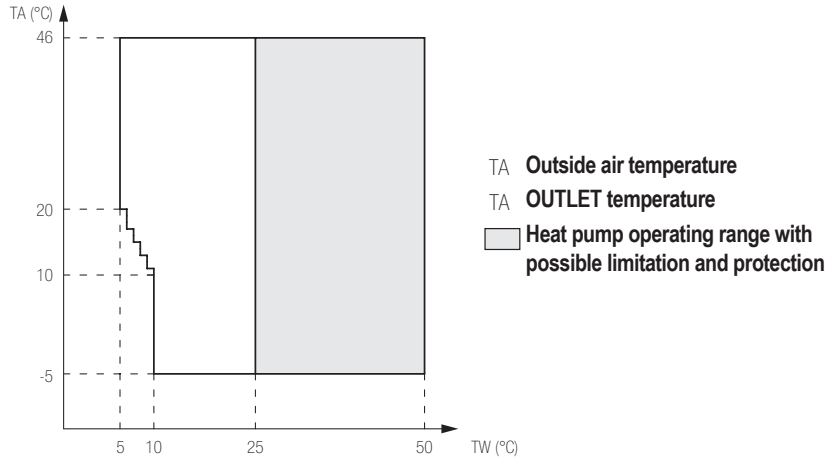

HEATING MODE

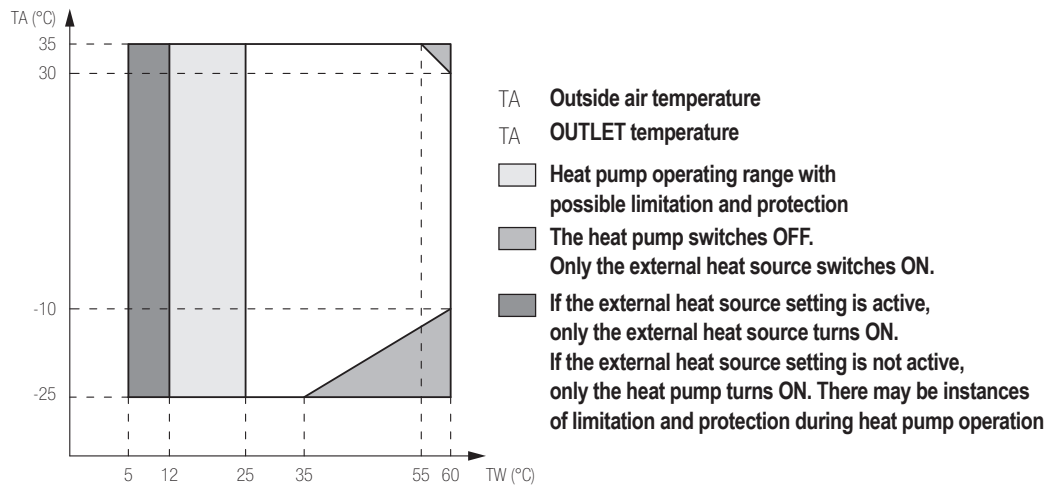

DHW MODE

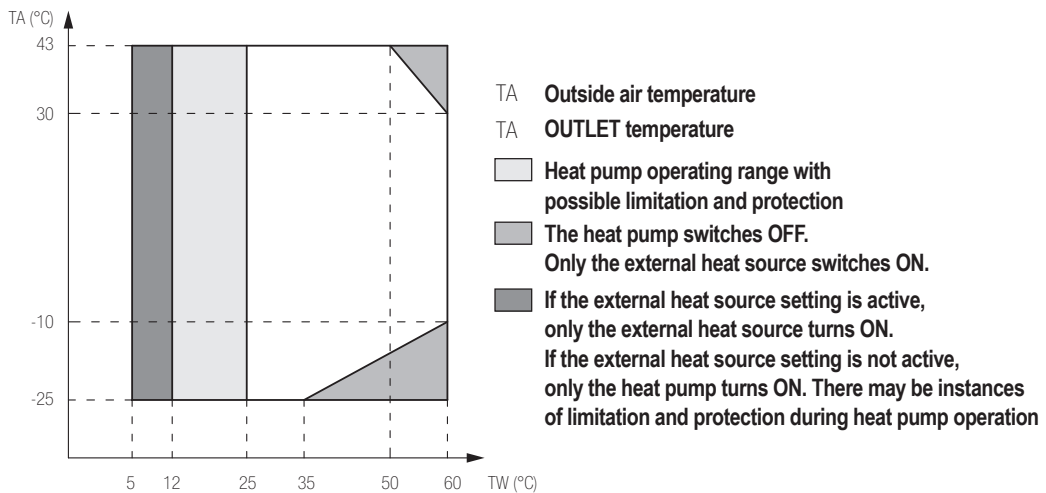

Product description

Sound pressure levels

Model	Hydro Unit M				
	UM	018T	022T	026T	030T
Sound pressure (1)	dB (2)	57,6	59,8	61,5	63,5

- (1) The sound pressure level is measured in a semi-anechoic chamber at a distance of 1m from front of the unit and a height above the floor $(1+H)/2m$, where H is the height of the unit in metres. During on-site operation, sound pressure levels may be higher because of ambient noise.
- (2) dB is the maximum value tested under the following conditions:
 Outside air temperature 7°C DB, 85% Rel. Hum.; EWT 30°C, LWT 35°C. Variable compressor frequency.
 Outside air temperature 7°C DB, 85% Rel. Hum.; EWT 47°C, LWT 55°C. Variable compressor frequency.

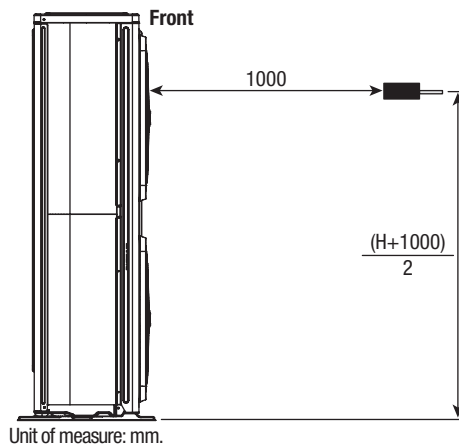

Sound pressure curves

- **Cooling at nominal frequency**
 Outside air temperature 35°C dry bulb - Water input temperature 12°C - Water output temperature 7°C.
- **Cooling at nominal frequency**
 Outside air temperature 35°C dry bulb - Water input temperature 23°C - Water output temperature 18°C.
- **Heating at nominal frequency**
 Outside air temperature 7°C dry bulb - Relative Humidity 85% - Water input temperature 30°C - Water output temperature 35°C.
- **Heating at nominal frequency**
 Outside air temperature 7°C dry bulb - Relative Humidity 85% - Water input temperature 40°C - Water output temperature 45°C.
- **Heating at nominal frequency**
 Outside air temperature 7°C dry bulb - Relative Humidity 85% - Water input temperature 47°C - Water output temperature 55°C.

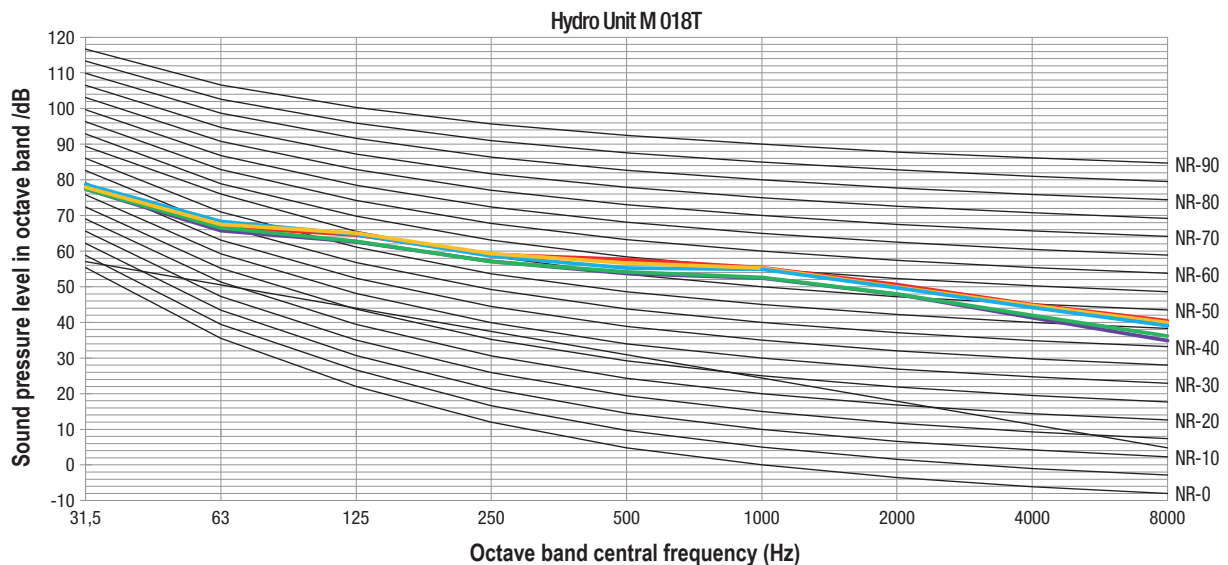

Product description

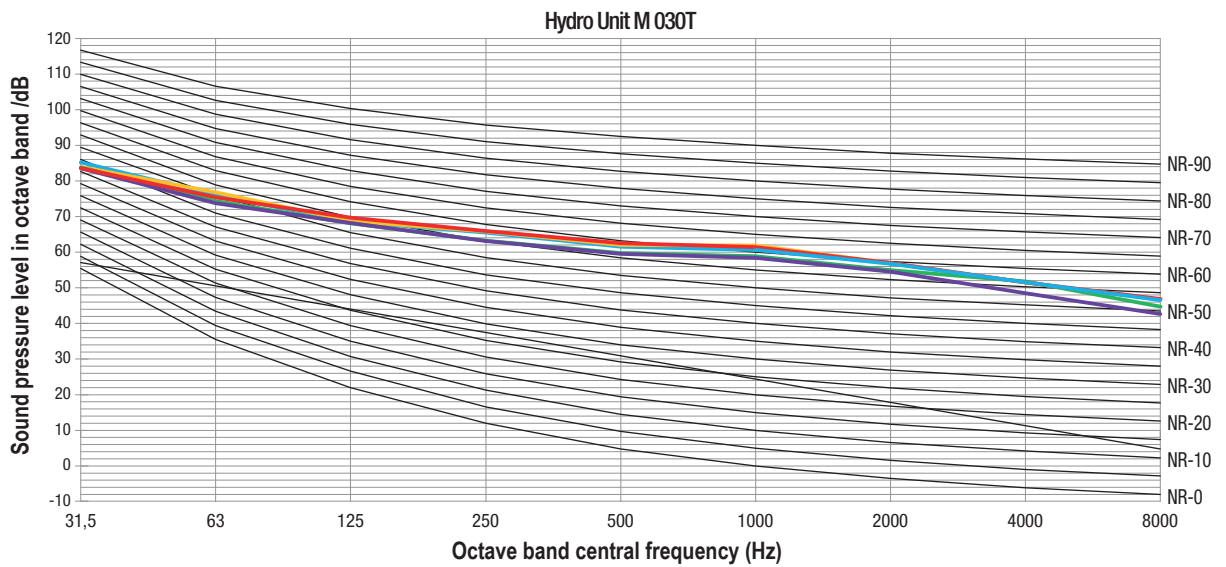
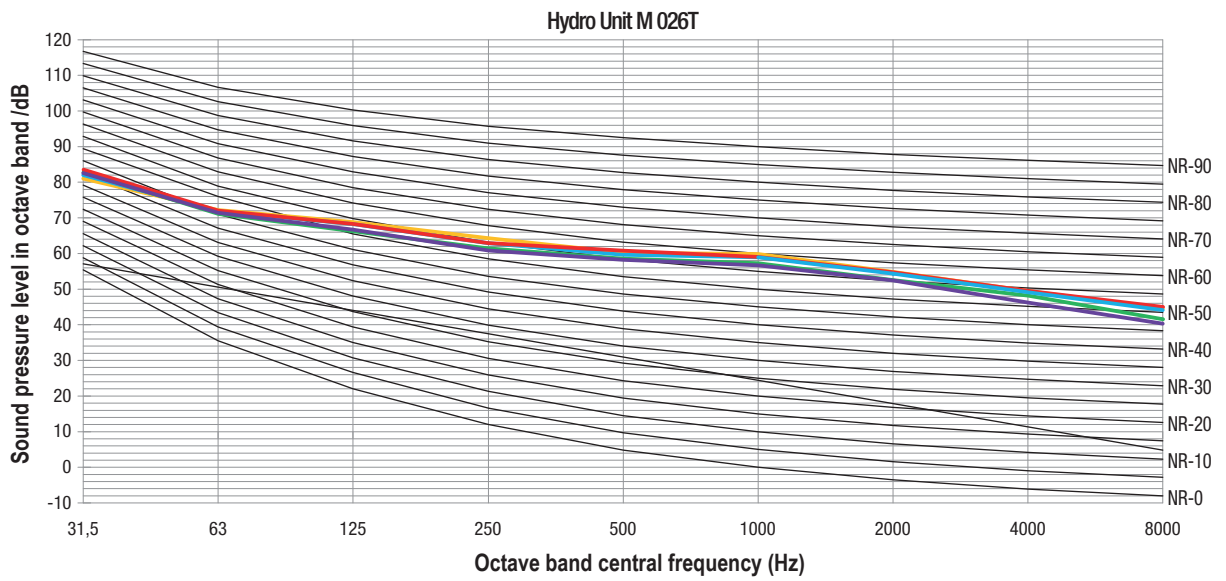
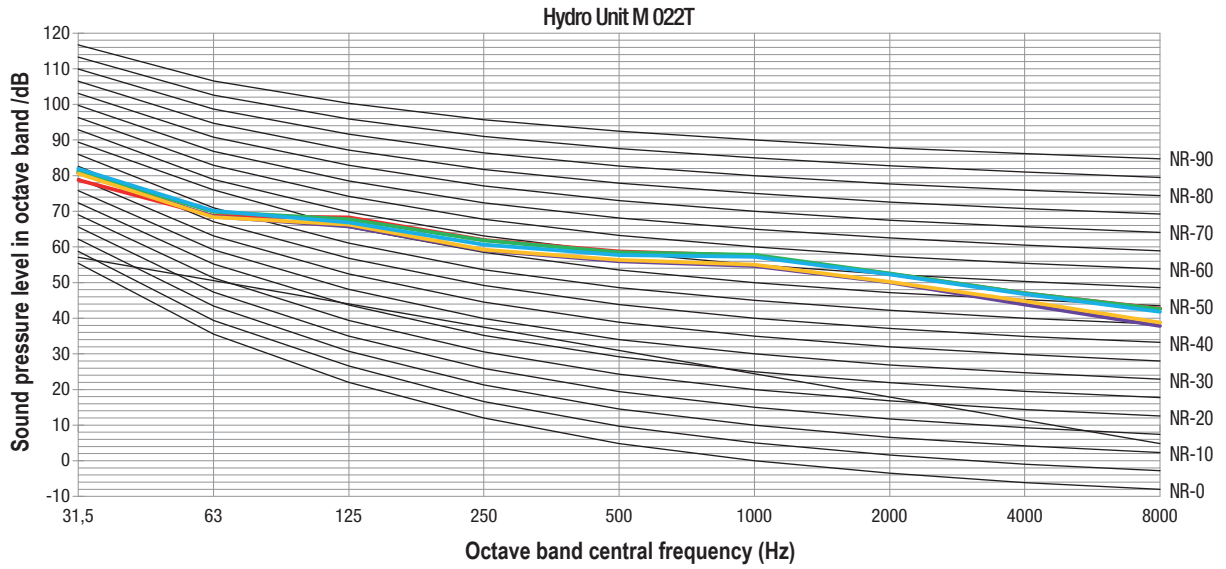

Dimensions and layouts

Overall dimensions

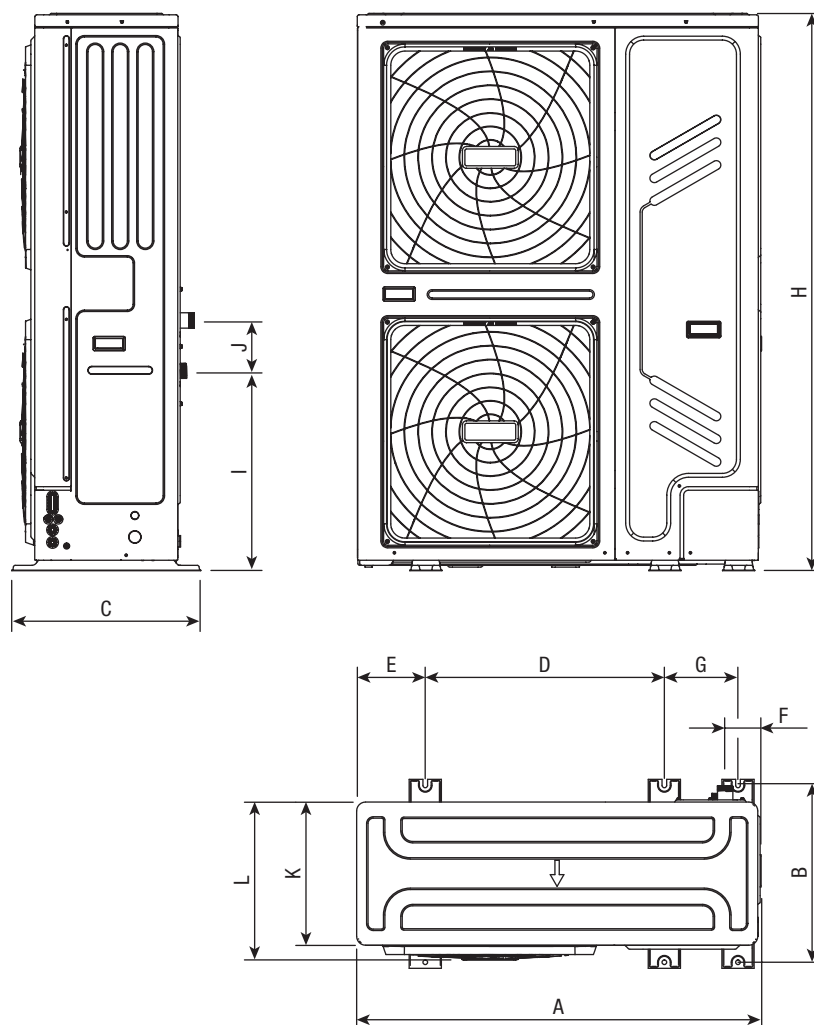

A	mm	1129
B	mm	494
C	mm	528
D	mm	668
E	mm	192
F	mm	98
G	mm	206
H	mm	1558
I	mm	558
J	mm	143
K	mm	400
L	mm	440

Dimensions and layouts

Place of installation

Under normal conditions

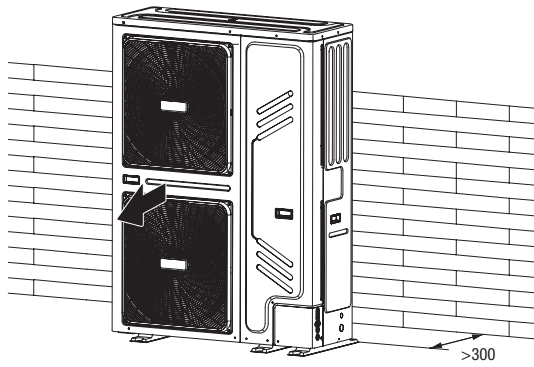

In strong wind conditions

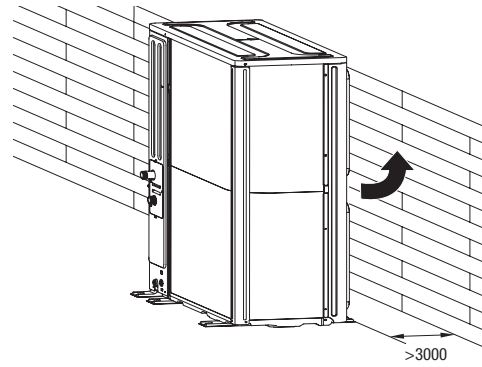

In cold weather conditions

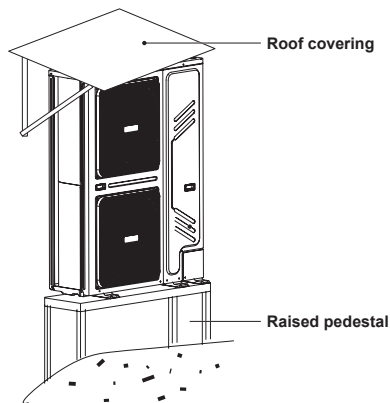

For parallel installation in a single row

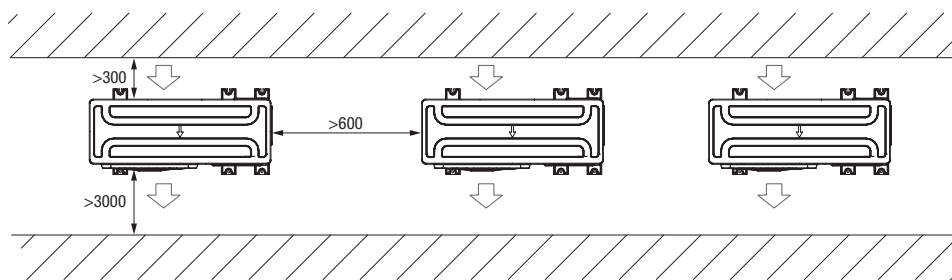

For parallel installation in a several row

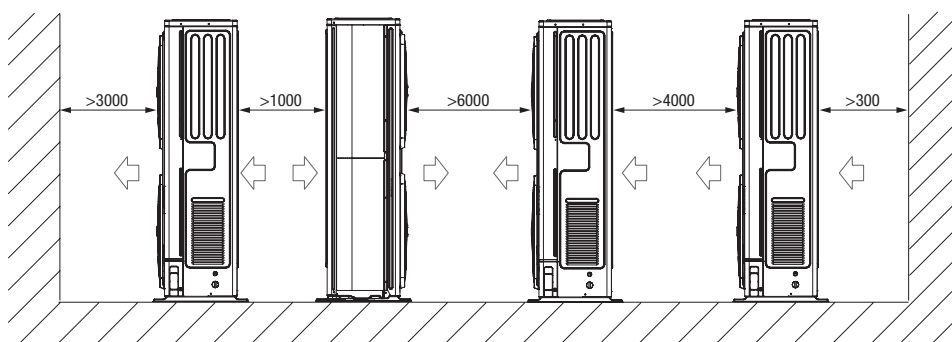

Dimensions and layouts

Hydronic module

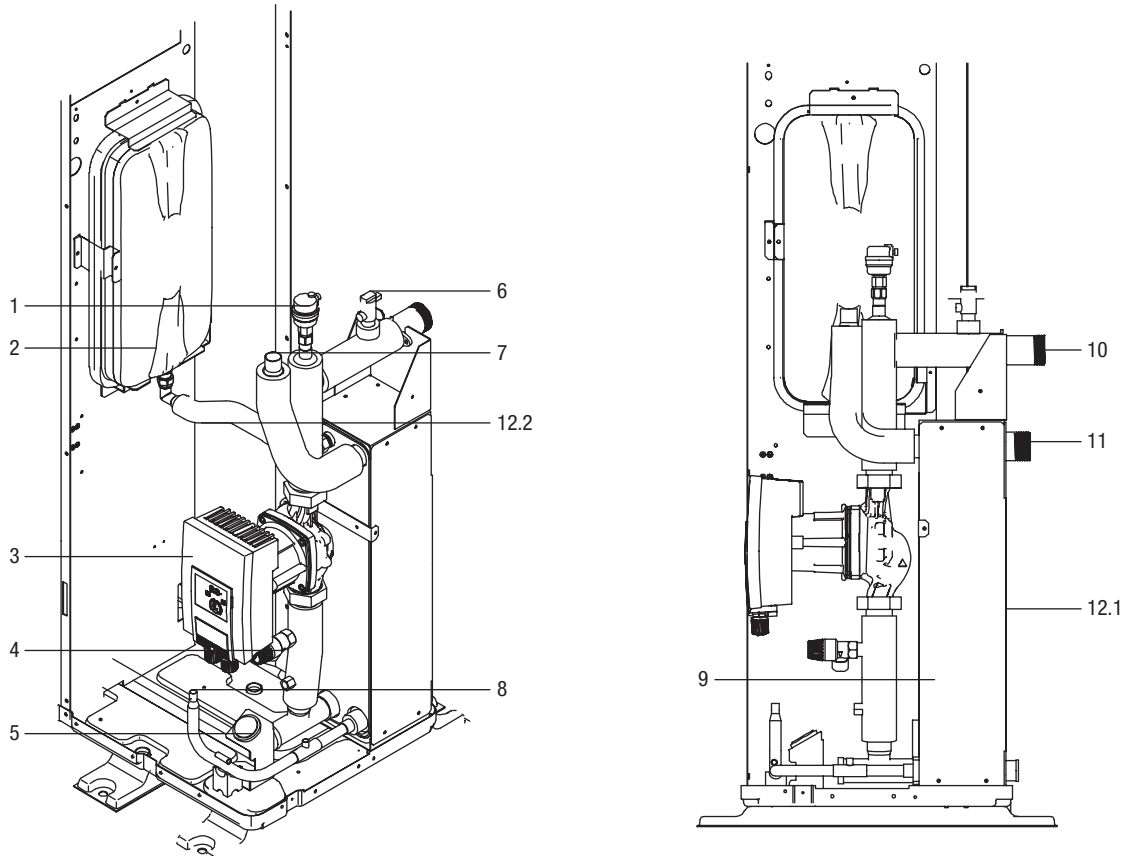

Assembly unit	Explanation
1 Air purge valve	Any air remaining in the water circuit will be automatically eliminated
2 Expansion tank	Balances the pressure of the water system (volume of the expansion vessel: 8 l)
3 Circulation pump	Enables the water to circulate in the dedicated circuit
4 Overpressure valve	Avoids any excessive water pressure by opening at 3 bar and draining the water from the dedicated circuit
5 Pressure gauge	Indicates the water circuit pressure reading
6 Flow meter	Measures the water flow rate to protect the compressor and water pump in the event of an insufficient water flow
7 Refrigerant gas connection	/
8 Coolant connection	/
9 Plate heat exchanger	Transfers heat from the refrigerant to the water
10 Water outlet connection	/
11 Water inlet connection	/
12.1 Electric heating tape	For the heated plate heat exchanger
12.2 Electric heating tape	For the expansion vessel heating connection pipe

Dimensions and layouts

Hydraulic connections

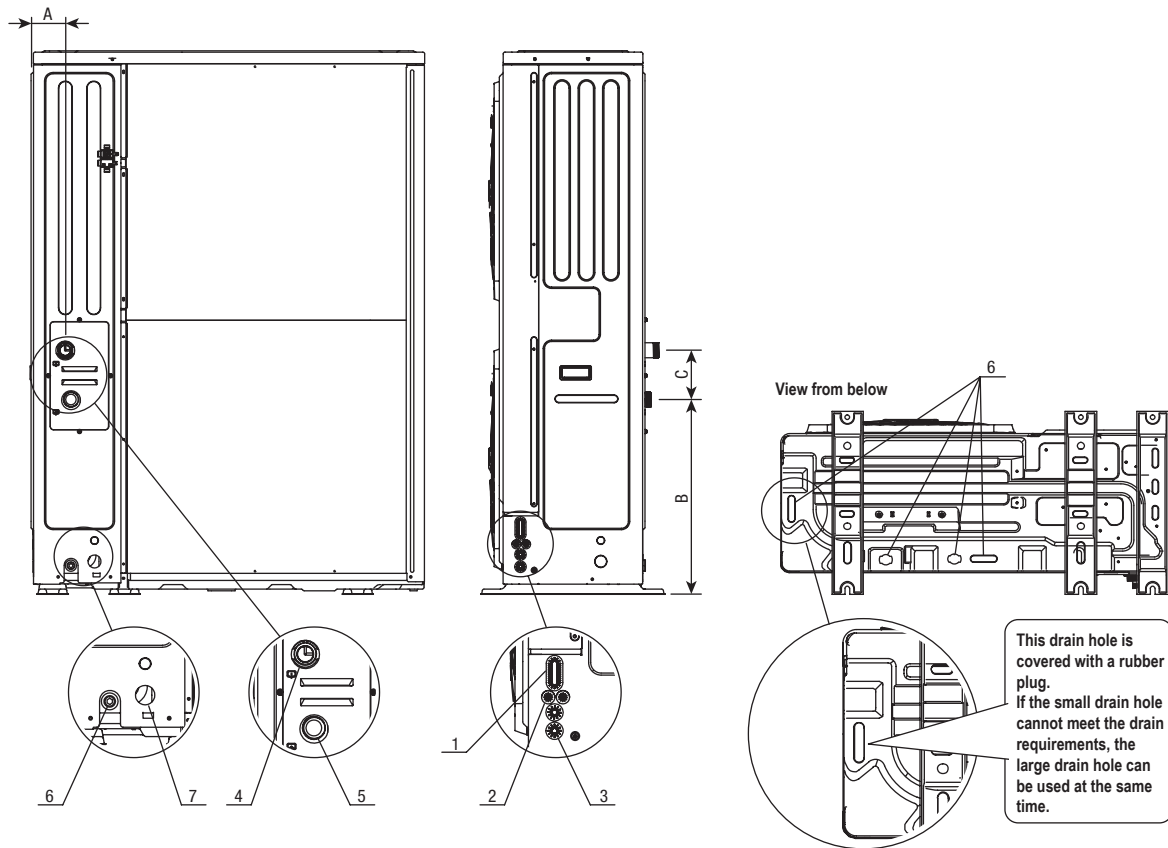

Model	UM	Hydro Unit M 018T - 030T
1 Hole for high voltage wire	Ø mm	25
2 Hole for low voltage wire	Ø mm	15
3 Hole for the high voltage or low voltage cable	Ø mm	15
4 Water outlet	Ø	1 1/4"
5 Water inlet	Ø	1 1/4"
6 Condensate drain hose coupling (supplied)	Ø mm	35
7 Hole for safety valve discharge pipe	Ø mm	15
A	mm	98
B	mm	558
C	mm	143

Dimensions and layouts

Flow rate-head-loss of load diagrams

The pump speed can be selected by adjusting the red knob on the pump. The point marked by the notch indicates the pump speed. The default setting is maximum speed (C3). If the water flow in the system is too high, the speed can be set to low (C1). The external static pressure function available for the water flow is shown in the following graph.

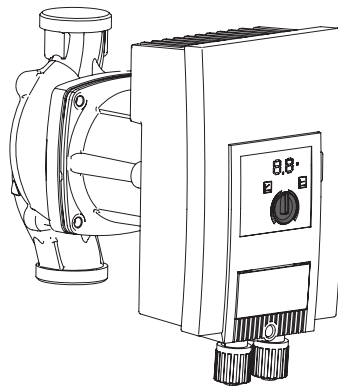

Model	UM	018T	022T	026T	030T
Effective pump head (A7; W35) (1)	kPa	100	92	78	58
Minimum water flow rate	m ³ /h	1,62	1,62	1,62	1,62
Maximum water flow rate	m ³ /h	3,90	4,70	5,00	5,40

(1) Outside air temperature 7°C DB, 6°C WB; water inlet/outlet 30/35°C.

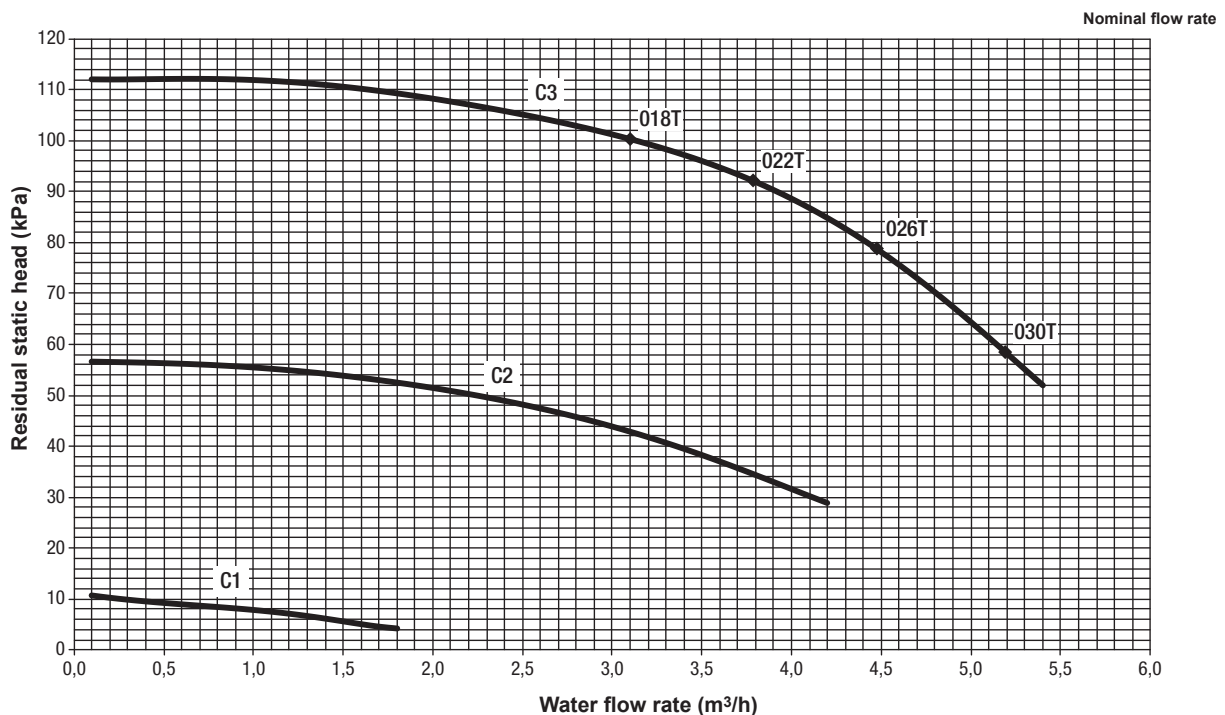

Dimensions and layouts

The water in the heating systems

Chemical and physical characteristics

The chemical and physical characteristics of water used in central heating systems must conform to the requirements of EN 14868 standard and to the following tables:

Plant water reference values		
pH	-	7,8
Electrical conductivity	µS/cm	10 600
Chloride ions	mg/l	< than 10
Sulphuric acid ions	mg/l	< than 30
Total iron	mg/l	< than 5
M alkalinity	mg/l	< than 100
Total hardness	mmol/l	1,2,5
Sulphur ions	-	none
Ammonia ions	-	none
Silicon ions	mg/l	< than 1

Well or groundwater not supplied from aqueducts must always be carefully analysed and, if necessary, conditioned with suitable treatment systems.

If the starting water is harder than the value indicated in the table, a water softening system must be used.

Excessive water softening (total hardness < 1,5 mmol/l) could result in corrosion caused by contact with metal elements (pipes or boiler components). Also keep conductivity values within 600 µS/cm.

Check the concentration of chlorides at the outlet after regenerating the resins.

It is absolutely forbidden to pour acids into the washing circuit.

The heating system must not be constantly or frequently topped up, since this can damage the appliance's heat exchanger.

Plant water content and flow rate

Heat pumps require systems that ensure a constant flow of fluid to the appliance within minimum and maximum values as well as sufficient volumes to avoid imbalances in the cooling circuits and to ensure a correct degree of comfort.

Plant water content

For correct operation of the appliance, a minimum volume of water must be ensured in the system's primary circuit.

A minimum volume is necessary to prevent the risk of ice forming during defrosting operations or continuous modulation of the compressor frequency.

It also provides the following advantages:

- Less wear of the appliance.
- Better system performance.
- Better temperature stability and precision.

Model	UM	018T	022T	026T	030T
System minimum water volume (1) (2)	l	40	40	40	40

(1) Excluding the unit's internal water volume.

(2) For cascade installations, the minimum volume must be $\geq 40 \text{ l} \cdot n$ where n is the number of units connected.

Dimensions and layouts

Wiring

Standard wiring component specifications

Control Panel 1: compressor and electrical component compartment: XT1.

Power supply for outdoor unit (1)					
Model	UM	018T	022T	026T	030T
Maximum overcurrent protection (MOP)	A	18	21	24	28
Wiring dimensions	mm ²	6	6	6	6

(1) The declared values are maximum values (see electrical data for exact values). The pre-set differential ground switch must be a high-speed circuit breaker at 30 mA (<0,1 s).

- Make the electrical connections using the required connector, as indicated in the detailed drawing.
- After making the connections, insert the connector in its counterpart.
- You are advised to use conductors with a section no larger than 0.5 mm².
- In the event of TA or TBT connection, remove the relative jumpers on the terminal board.

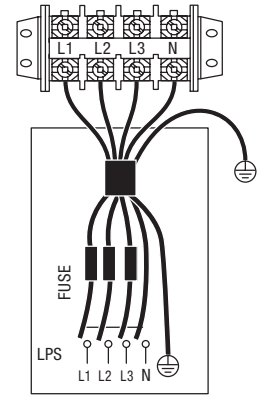

POWER SUPPLY 380VAC-3N

Parallel system connection (cascade)

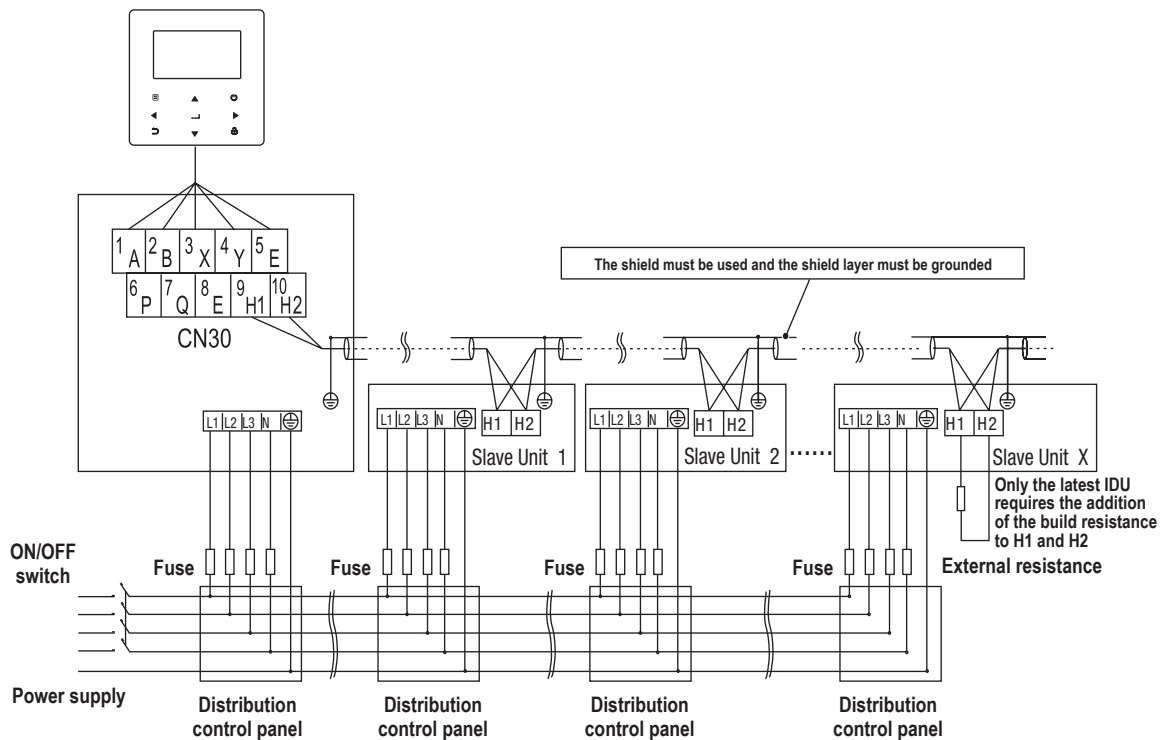

The system's parallel function supports up to max. 6 units.

To ensure that automatic addressing is successful, all units must be connected to the same power supply and powered up uniformly.

Only the Master unit can connect the controller and SW9 of the Master unit must be set to "ON"; the slave unit cannot connect the controller.

Shielded wire must be used and the shield layer must be grounded.

Dimensions and layouts

Connections for other components

For the electrical wiring details, refer to the product INSTALLER manual.

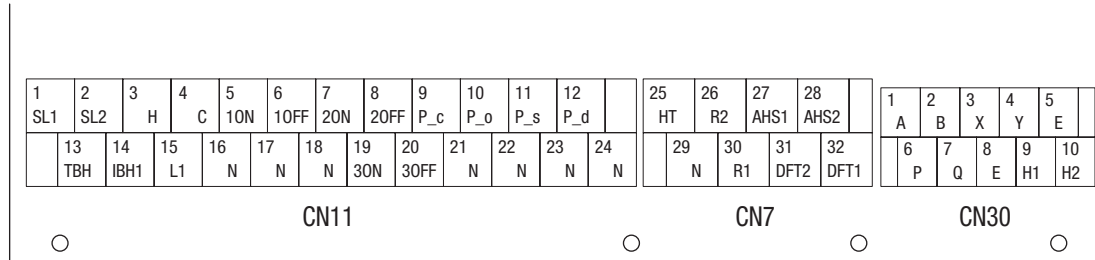

CODE	PRINT	CONNECTION TO
1	1 SL1	Solar energy input signal
	2 SL2	
2	3 H	Room thermostat input (high voltage)
	4 C	
3	15 L1	SV1 (3-way valve)
	16 N	
4	7 20N	SV2 (3-way valve)
	8 20FF	
5	9 P_c	Pump c (zone 2 pump)
	21 N	
6	10 P_o	External circulation pump (zone 1 pump)
	22 N	
7	11 P_s	Solar energy pump
	23 N	
8	12 P_d	DHW tube pump
	24 N	
9	13 TBH	Tank booster heater
	16 N	
10	14 IBH1	Internal backup heater 1
	17 N	
11	18 N	SV3 (3-way valve)
	19 30N	
	20 30FF	

CODE	PRINT	CONNECTION TO
1	26 R2	Compressor operation
	30 R1	
	31 DFT2	Defrosting operation
	32 DFT1	
2	25 HT	Anti-freeze heating resistor (external)
	29 N	
3	27 AHS1	Additional heating source
	28 AHS2	
1	1 A	Wired control panel
	2 B	
	3 X	
	4 Y	
	5 E	
2	6 P	Outdoor unit
	7 Q	
3	8 E	Units connected in cascade
	9 H1	
	10 H2	

The port supplies the load with the control signal.

Two types of control signal port:

Type 1: Non-powered contact (relay type).

Type 2: The port supplies a 220V voltage signal. If the load current is <0.2 A, the load can be connected directly to the port. If the load current is ≥0,2A, the AC contactor must be connected for the load.

Control panel

The control panel is the interface for the installation technician and the user to implement all the operating parameter setting tasks and display the status of the components in the appliance.

Based on the temperatures detected by the probes fitted in the appliance and by those that may be installed in the domestic hot water boiler, in the room and outside, the electronic systems modulate the operation of the appliance and its operating condition can be viewed on the display.

The control panel can be used to set the temperature required for the system and for domestic hot water.

Hydro Unit M T can be controlled through:

- Control panel
- External enables
- Modbus RTU

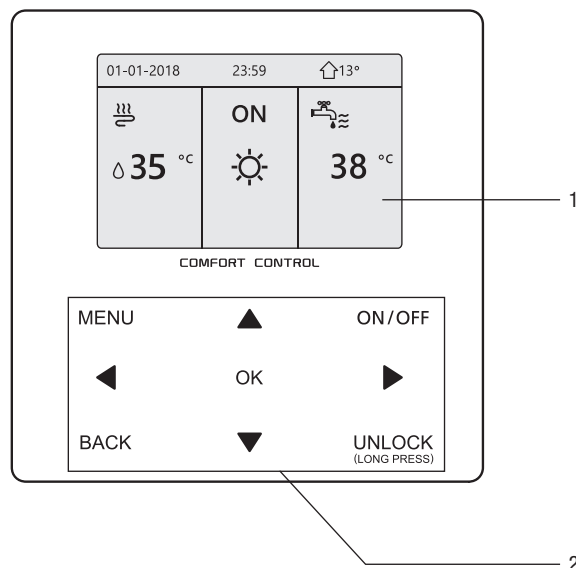

Info	Description
MENU	Go to the menu structure (on the home page).
◀▶▼▲	Move the cursor on the display. Navigate through the menu structure. Adjust the settings.
ON/OFF	Activate/deactivate room heating/cooling operation or DHW mode. Activate or deactivate functions in the menu structure.
BACK	Go back to the upper level.
UNLOCK	Press and hold to unlock/lock the controller. Unlock/lock certain functions such as "DHW temperature adjustment".
OK	Go to the next step when setting a program in the menu structure. Confirm a selection to access a sub-menu in the menu structure

Specifications guide

HYDRO UNIT M T

Outdoor monobloc air-water heat pump, three-phase, with DC-inverter control and MITSUBISHI twin rotary compressor for all sizes to guarantee optimum dynamic balancing and reduce vibration, with continuous modulation from approx. 40% to 120%, designed to work with R32 refrigerant gas.

Given the wide operating range, it's ideal for every type of system, whether hybrid or monovalent. In heating mode in fact, it can supply water at 60°C with an outdoor temperature as low as -10°C, and in cooling mode water at 7°C with an outdoor temperature up to 46°C, and can also produce domestic hot water thanks to storage tanks and fixed coils or heat exchangers for instantaneous DHW production, as it can supply delivery water at 50°C with a temperature of 43°C outside.

Top level performance. Up to A+++ for low temperatures and A++ for medium temperatures in temperate zones, according to EN 14825_2016. All the performance values are certified by HP Keymark, MCS.

Built in accordance with the European eco-design regulations, that define the requisites for the ERP (Energy Related Products) standard in order to improve energy efficiency.



Characteristics

- HYDRO UNIT M 018T-030T provides an extremely high level of energy efficiency in both heating and cooling mode, thereby guaranteeing significant energy savings. The large, high-efficiency coils, together with the optimised circuits, ensure results that meet the European tax relief requisites. Efficiency levels in partial load conditions (seasonal energy efficiency) are the highest in this industrial sector.
- Comfort throughout the year: the ground-breaking technology implemented in HYDRO UNIT M boosts comfort levels for users in terms of water temperature control and quiet operation alike. The required temperature is reached quickly and kept constant, without any fluctuations. HYDRO UNIT M T offers optimised, personalised comfort levels both in winter and in summer.
- Hydro Unit M can work in cooling mode even with low outdoor temperatures (from -5°C, and up to 43°C). To ensure the maximum comfort for the user, the units work in heating mode with outdoor temperatures down to -25°C, whereas in summer they can produce hot water up to 50°C for DHW applications, with the outdoor temperature as high as 43°C.
- In the ambient comfort modes (both heating and cooling), weekly programming is a standard feature.
- In the DHW modes, weekly programming and an anti-legionella function - with thermal disinfection - are available as standard.
- A multitude of possible system layouts. Thanks to the sensors available as accessories, the unit can manage - for example - a solar system, one or two zones (one of them mixed) and DHW recirculation.

Specifications guide

- The possibility to link up to 6 units in a cascade. In cascade configurations, the master unit can be dedicated to DHW production.
- A USB port is available for updating the electronic board software.
- A clean input is available, dedicated to smart grid functions.
- Operation guaranteed with at least 40lt of water in the system.

Structure

- Cabinet made of sheet steel painted with neutral-coloured powders (RAL 7044) to enhance resistance to corrosion caused by atmospheric agents. All the panels are removable.

Compressor

- The compressor has a double protective sound insulation shield to further reduce the noise levels. Advanced technology ensuring optimum energy efficiency and characterised by high output levels in peak conditions and optimised efficiency at low and medium compressor speeds. The Hydro Unit M T heat pump uses DC inverter technology that combines two electronic adjustment logics, pulse amplitude modulation (PAM) and pulse width modulation (PWM), to guarantee optimised compressor operation in all working conditions, minimise temperature fluctuation and ensure perfect comfort adjustment whilst at the same time considerably reducing energy consumption.
 - PAM: the modulation of the direct current pulse amplitude commands the compressor to work in maximum load conditions (start-up and peak load) so as to increase the voltage in the case of a fixed frequency. The compressor works at high speed to quickly reach the required temperature.
 - PWM: the modulation of the direct current pulse width commands the compressor to work in partial load conditions, adapting the frequency in the case of a fixed voltage. The compressor speed is precisely adjusted and the system offers a high comfort level (no temperature fluctuations) in working conditions of outstanding efficiency.
- The compressor frequency increases constantly until it reaches the maximum level. This ensures that there are no intensity peaks during the start-up phase, and also means a secure connection to the single-phase current supply even for high-output systems. This compressor start logic makes “soft start” starter devices unnecessary, at the same time guaranteeing that the maximum output is available immediately.

External coil

- The external coil is made of copper pipes and hydrophilic aluminium fins. This solution makes it easier for the water to move towards the bottom of the heat exchanger, by means of gravity. In particular, this innovation means:
 - frost takes longer to form, so it doesn't build up so much on the coil;
 - the defrosting phase is more efficient thanks to improved water runoff on the fins (and this boosts operation in heating mode).
- Blue Coating treatment is applied as standard to improve the resistance of the coils to corrosive agents, and is recommended in all applications where there is a moderate risk of corrosion.

External fan

- Single DC brushless fan motor with variable speed for optimum air distribution and extremely low noise levels. The possibility to set two different maximum noise levels.

Electronic expansion valve

- The expansion valve is an electronic twin-flow expansion device that optimises the volume of coolant in the circuit and consequently overheating, thereby preventing the fluid returning in liquid status to the compressor. This device further improves the high efficiency and reliability of the system, since it allows operation even with very low condensing pressures throughout the work range.

Solenoid valve

- Given the wide operating range of the unit, the solenoid valve (fully managed by the unit itself) allows the compressor to work at optimum temperature levels at all times.

Plate heat exchanger

- Vertical plate heat exchanger in AISI 316 stainless steel.

Built-in hydronic unit

- In domestic applications, there is the possibility to connect the inertial storage tank directly underneath the unit to minimise the space taken up. All the internal hydronic parts are insulated to reduce heat loss. The anti-freeze program contains special functions that use the heat pump and backup heater (if installed) to protect the entire system from the risk of freezing. When the water flow temperature in the system falls to a certain value, the unit heats the water using both the heat pump and the electric heating tap (and also the backup heater, if installed). The anti-freeze protection function is only deactivated when the temperature rises to a certain value.



RIELLO S.p.A.
Via Ing. Pilade Riello, 7
37045 Legnago (VR) – Italy
tel. +39 0442 630111

www.berettaheating.com

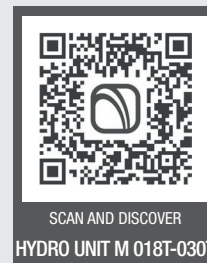

Beretta reserves the right to change the information and specifications contained herein at any time and without notice. The contents and information contained herein are for informational purposes only and are not intended to provide legal or professional advice. Therefore, this document cannot be considered binding towards third parties.

© Riello S.p.A. All rights reserved