

HYDRO UNIT M

Heat pumps

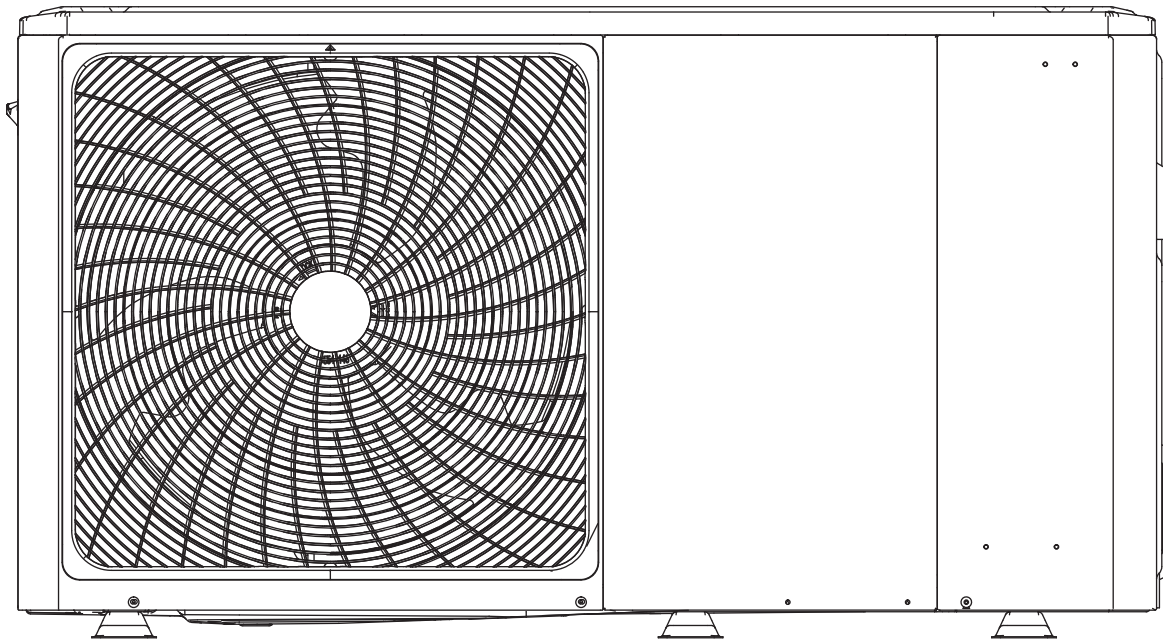

Contents

General introduction	4
Specifications guide	5
Technical data	7
Operating range	23
Description and use of the appliance	25
Electric wiring	28
Typical applications	32

General introduction

- These units are used for both heating and cooling applications and for DHW tanks. They can be combined with fan coils, floor heating applications, specific radiators guaranteeing high efficiency at low temperatures, DHW tanks and solar kits (all powered on-site).
- The unit comes with a wired control panel.
- If a built-in backup heater is installed, it can increase the heating capacity when outdoor temperatures are particularly low. It also acts as a backup in the event of operating faults, and as an anti-freeze protection for the external water piping during the winter.

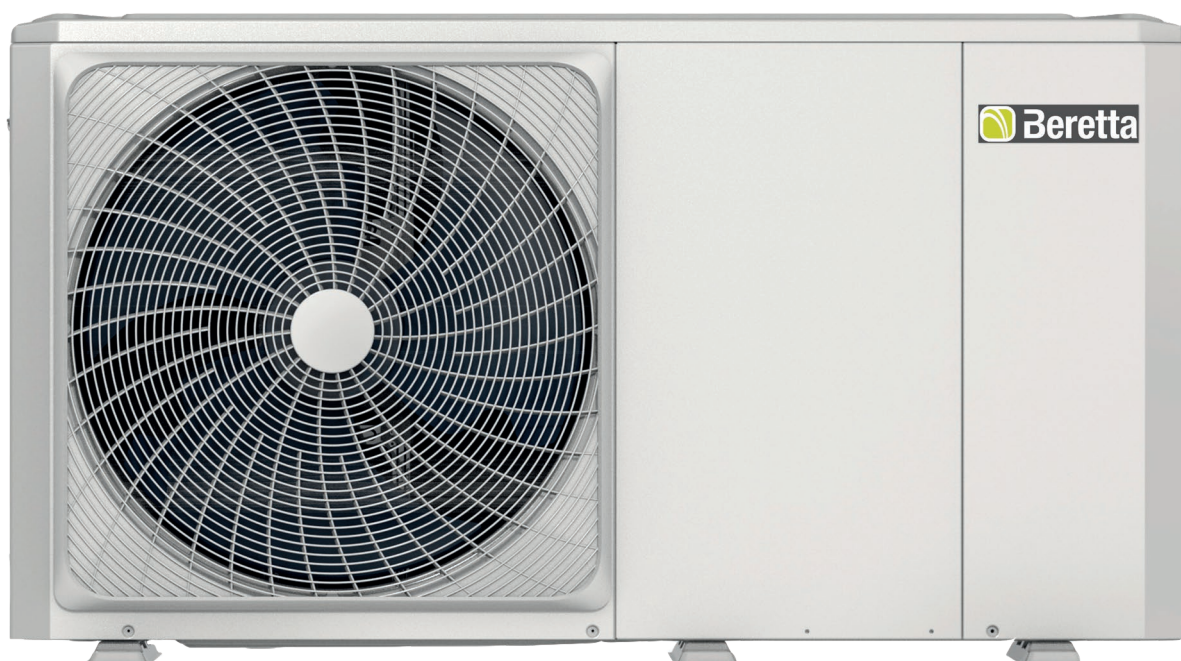

Specifications guide

Outdoor monobloc air-water heat pump, single-phase and three-phase, with DC-inverter control and MITSUBISHI twin rotary compressor for all sizes to guarantee optimum dynamic balancing and reduce vibration, with continuous modulation from approx. 40% to 120%, designed to work with R32 refrigerant gas.

Given the wide operating range, it's ideal for every type of system, whether hybrid or monovalent. In heating mode in fact, it can supply water at 60°C with an outdoor temperature as low as -15°C, and in cooling mode water at 7°C with an outdoor temperature up to 43°C, and can also produce domestic hot water thanks to storage tanks and fixed coils or heat exchangers for instantaneous DHW production, as it can supply delivery water at 55°C with a temperature of 43°C outside. Top level performance. Up to A+++ for low temperatures and A++ for medium temperatures in temperate zones, according to EN 14825_2016. All the performance values are certified by HP Keymark, MCS.

Built in accordance with the European eco-design regulations, that define the requisites for the ERP (Energy Related Products) standard in order to improve energy efficiency.

Unit components

Structure

- Cabinet made of sheet steel painted with neutral-coloured powders (RAL 7035) to enhance resistance to corrosion caused by atmospheric agents. All the panels are removable.

Compressor

- A high-efficiency MITSUBISHI twin rotary DC inverter compressor is installed on every size. The two rotating blades of the compressor are dephased by 180°. Along with the DC brushless motor, fitted with a perfectly balanced shaft, they guarantee that noise and vibrations are kept at a minimum even at extremely low operating speeds.
- The compressor has a double protective sound insulation shield to further reduce the noise levels.
- Advanced technology ensuring optimum energy efficiency and characterised by high output levels in peak conditions and optimised efficiency at low and medium compressor speeds. The HDYRO UNIT M heat pump uses DC inverter technology that combines two electronic adjustment logics, pulse amplitude modulation (PAM) and pulse width modulation (PWM), to guarantee optimised compressor operation in all working conditions, minimise temperature fluctuation and ensure perfect comfort adjustment whilst at the same time considerably reducing energy consumption.
- PAM: the modulation of the direct current pulse amplitude commands the compressor to work in maximum load conditions (start-up and peak load) so as to increase the voltage in the case of a fixed frequency. The compressor works at high speed to quickly reach the required temperature.
- PWM: the modulation of the direct current pulse width commands the compressor to work in partial load conditions, adapting the frequency in the case of a fixed voltage. The compressor speed is precisely adjusted and the system offers a high comfort level (no temperature fluctuations) in working conditions of outstanding efficiency.
- The compressor frequency increases constantly until it reaches the maximum level. This ensures that there are no intensity

peaks during the start-up phase, and also means a secure connection to the single-phase current supply even for high-output systems. This compressor start logic makes “soft start” starter devices unnecessary, at the same time guaranteeing that the maximum output is available immediately.

External coil

The external coil is made of copper pipes and hydrophilic aluminium fins. This solution makes it easier for the water to move towards the bottom of the heat exchanger, by means of gravity.

In particular, this innovation means:

- frost takes longer to form, so it doesn't build up so much on the coil;
- the defrosting phase is more efficient thanks to improved water runoff on the fins (and this boosts operation in heating mode).
- Blue Coating treatment is applied as standard to improve the resistance of the coils to corrosive agents, and is recommended in all applications where there is a moderate risk of corrosion.

External fan

Single DC brushless fan motor with variable speed for optimum air distribution and extremely low noise levels. The possibility to set two different maximum noise levels.

Electronic expansion valve

The electronic expansion valve is a dual flow electronic expansion device whose job is to optimise the volume of the refrigerant fluid in the circuit and therefore the overheating issue, preventing the fluid from returning to the compressor. This device further boosts the high efficiency and reliability of the system as it enables it to work even with very low condensation pressure values across the whole operating range.

Solenoid valve

Given the wide operating range of the unit, the solenoid valve (fully managed by the unit itself) allows the compressor to work at optimum temperature levels at all times.

General introduction

Plate heat exchanger

Vertical plate heat exchanger in AISI 316 stainless steel.

Built-in hydronic unit

The hydronic module is always installed. It's supplied with a variable speed circulation pump, a flow switch, a 3 bar safety valve, an expansion tank and water temperature probes (inlet and outlet). A backup electric heater is available as an accessory. In domestic applications, there is the possibility to connect the inertial storage tank directly underneath the unit to minimise the space taken up.

All the internal hydronic parts are insulated to reduce heat loss. The anti-freeze program contains special functions that use the heat pump and backup heater (if installed) to protect the entire system from the risk of freezing. When the water flow temperature in the system falls to a certain value, the unit heats the water using both the heat pump and the electric heating tap (and also the backup heater, if installed). The anti-freeze protection function is only deactivated when the temperature rises to a certain value.

Main characteristics

- HYDRO UNIT M provides an extremely high level of energy efficiency in both heating and cooling mode, thereby guaranteeing significant energy savings. The large, high-efficiency coils, together with the optimised circuits, ensure results that meet the European tax relief requisites. Efficiency levels in partial load conditions (seasonal energy efficiency) are the highest in this industrial sector.
- Comfort throughout the year: the ground-breaking technology employed for HYDRO UNIT M means boosted comfort levels for users in terms of both water temperature control and quiet operation. The required temperature is reached quickly and kept constant, without any fluctuations. HYDRO UNIT M offers optimised, personalised comfort levels both in winter and in summer.
- HYDRO UNIT M can work in cooling mode even with low outdoor temperatures (from -25°C, and up to 43°C). To ensure the maximum comfort for the user, the units work in heating mode with outdoor temperatures down to -25°C, whereas in summer

they can produce hot water up to 50°C for DHW applications, with the outdoor temperature as high as 43°C.

- In the ambient comfort modes (both heating and cooling), weekly programming is a standard feature.
- In the DHW modes, weekly programming and an anti-legionella function - with thermal disinfection - are available as standard.
- A multitude of possible system layouts. Thanks to the sensors available as accessories, the unit can manage - for example - a solar system, one or two zones (one of them mixed) and DHW recirculation.
- The possibility to link up to 6 units in a cascade. In cascade configurations, the master unit can be dedicated to DHW production.
- USB port available for updating the technical board software.
- A clean input is available, dedicated to smart grid functions.
- Operation guaranteed with at least 40lt of water in the system.

Standards

The HYDRO UNIT M heat pumps comply with the following European directives:

- Electromagnetic Compatibility Directive (EMC) 2014/30/EU, and subsequent variations.
- Low Voltage Directive 2014/35/EU.
- Machinery Directive 2006/42/EC, and subsequent variations (only for the 12-16kW model).
- Pressure Equipment Directive (PED) 2014/68/EU (only for the 12-16kW model).
- RoHS Directive 2011/65/EU.
- ErP Directive 2009/125/EC and Regulation (EU) 813/2013.
- F-gas Regulation 2014/517/EU.
- Energy Labelling Regulation 2017/1369/EU.

Technical data

Description	UM	HYDRO UNIT M 4	HYDRO UNIT M 6	HYDRO UNIT M 8	HYDRO UNIT M 10
Performance data in heating					
Performance in heating (A7°C; W35°C)					
Nominal capacity	kW	4,20	6,35	8,40	10,00
Input power	kW	0,82	1,28	1,63	2,02
COP		5,10	4,95	5,15	4,95
SCOP (temperate zone)		4,85	4,95	5,21	5,19
Seasonal energy efficiency	%	191	195	205	205
Energy class		A+++	A+++	A+++	A+++
Performance in heating (A7°C; W45°C)					
Nominal capacity	kW	4,30	6,30	8,10	10,00
Input power	kW	1,13	1,70	2,10	2,67
COP		3,80	3,70	3,85	3,75
Performance in heating (A7°C; W55°C)					
Nominal capacity	kW	4,40	6,00	7,50	9,50
Input power	kW	1,49	2,03	2,36	3,06
COP		2,95	2,95	3,18	3,10
SCOP (temperate zone)		3,31	3,52	3,36	3,49
Seasonal energy efficiency	%	130	138	132	137
Energy class		A++	A++	A++	A++
Performance data in cooling					
Performance in cooling (A35°C; W7°C)					
Nominal capacity	kW	4,70	7,00	7,45	8,20
Input power	kW	1,36	2,33	2,22	2,52
EER		3,45	3,00	3,35	3,25
SEER		4,99	5,34	5,83	5,98
Seasonal energy efficiency	%	196	210	230	235
Performance in cooling (A35°C; W18°C)					
Nominal capacity	kW	4,50	6,50	8,30	9,90
Input power	kW	0,82	1,35	1,64	2,18
EER		5,50	4,80	5,05	4,55
Electrical characteristics					
Electrical supply	V/ph/Hz	230/1/50	230/1/50	230/1/50	230/1/50
Total maximum input power ⁽¹⁾	kW	2,30	2,70	3,40	3,70
Total maximum input current ⁽²⁾	A	12,00	14,00	16,00	17,00
Compressor					
Compressor	Type/brand	DC twin rotary/ Mitsubishi	DC twin rotary/ Mitsubishi	DC twin rotary/ Mitsubishi	DC twin rotary/ Mitsubishi
Adjustment	Type	Inverter modulating	Inverter modulating	Inverter modulating	Inverter modulating
Minimum capacity control	%	55	43	40	38
Refrigerant	Type	R32	R32	R32	R32
GWP	CO ₂ equiv. in t/kg	675	675	675	675
Refrigerant load	kg	1,40	1,40	1,40	1,40
Control box load	CO ₂ equiv. in t	0,95	0,95	0,95	0,95
Number of circuits	no.	1	1	1	1
Hermetically sealed control box (EU reg. 517_2014)	yes / no	yes	yes	yes	yes

Technical data

Description	UM	HYDRO UNIT M 4	HYDRO UNIT M 6	HYDRO UNIT M 8	HYDRO UNIT M 10
Fan					
Fan	Type	DC axial	DC axial	DC axial	DC axial
Quantity	no.	1	1	1	1
Maximum air flow rate	m ³ /h	2770	2770	4030	4030
Heat exchanger (source side)					
Heat exchanger (source side)	Type	Pipes in copper, fins in aluminium with anti-corrosion treatment	Pipes in copper, fins in aluminium with anti-corrosion treatment	Pipes in copper, fins in aluminium with anti-corrosion treatment	Pipes in copper, fins in aluminium with anti-corrosion treatment
Circulation pump					
Circulation pump	Type	Variable speed centrifuge	Variable speed centrifuge	Variable speed centrifuge	Variable speed centrifuge
Nominal delivery	m ³ /h	0,72	1,09	1,44	1,72
Maximum operating pressure	bar	3	3	3	3
Maximum input power	kW	0,043	0,043	0,043	0,043
Maximum input current	A	0,44	0,44	0,44	0,44
Expansion tank volume	l	8,00	8,00	8,00	8,00
Heat exchanger (system side)					
Heat exchanger (system side)	Type	Plate, in stainless steel	Plate, in stainless steel	Plate, in stainless steel	Plate, in stainless steel
Total water content	l	2,16	2,16	2,44	2,44
Sound data					
Sound output ⁽³⁾	dB(A)	55	58	59	60
Sound pressure at 1m ⁽⁴⁾	dB(A)	45	47,5	48,5	50,5
Weight					
Net weight	kg	86	86	105	105

The performance values comply with Standards UNI EN 14511:2018 and UNI EN 14825:2016. Performance data certified by HP Keymark.

(1) Input power from compressors and from fans and circulator in the maximum operating conditions, with the nominal power supply voltage.

(2) Maximum unit operating current with the nominal power supply voltage.

(3) Sound emission values declared, in accordance with standard EN 12102-1.

(4) Measured in a semi-anechoic chamber, at a distance of 1m from the front of the unit and a height from the floor equal to (1+H)/2, where H is the height of the unit expressed in metres.

Technical data

Description	UM	HYDRO UNIT M 12	HYDRO UNIT M 14	HYDRO UNIT M 16	HYDRO UNIT M 12T	HYDRO UNIT M 14T	HYDRO UNIT M 16T
Performance data in heating							
Performance in heating (A7°C; W35°C)							
Nominal capacity	kW	12,10	14,50	15,90	12,10	14,50	15,90
Input power	kW	2,44	3,15	3,53	2,44	3,15	3,53
COP		4,95	4,60	4,50	4,95	4,60	4,50
SCOP (temperate zone)		4,81	4,72	4,62	4,81	4,72	4,62
Seasonal energy efficiency	%	189	186	182	189	186	182
Energy class		A+++	A+++	A+++	A+++	A+++	A+++
Performance in heating (A7°C; W45°C)							
Nominal capacity	kW	12,30	14,10	16,00	12,30	14,10	16,00
Input power	kW	3,32	3,92	4,57	3,32	3,92	4,57
COP		3,70	3,60	3,50	3,70	3,60	3,50
Performance in heating (A7°C; W55°C)							
Nominal capacity	kW	11,90	13,80	16,00	11,90	13,80	16,00
Input power	kW	3,90	4,68	5,61	3,90	4,68	5,61
COP		3,05	2,95	2,85	3,05	2,95	2,85
SCOP (temperate zone)		3,45	3,47	3,41	3,45	3,47	3,41
Seasonal energy efficiency	%	135	136	133	136	136	134
Energy class		A++	A++	A++	A++	A++	A++
Performance data in cooling							
Performance in cooling (A35°C; W7°C)							
Nominal capacity	kW	11,50	12,40	14,00	11,50	12,40	14,00
Input power	kW	4,18	4,96	5,60	4,18	4,96	5,60
EER		2,75	2,50	2,50	2,75	2,50	2,50
SEER		4,89	4,86	4,69	4,86	4,83	4,67
Seasonal energy efficiency	%	193	191	185	191	190	184
Performance in cooling (A35°C; W18°C)							
Nominal capacity	kW	12,00	13,50	14,20	12,00	13,50	14,20
Input power	kW	3,04	3,75	4,38	3,04	3,75	4,38
EER		3,95	3,61	3,61	3,95	3,61	3,61
Electrical characteristics							
Electrical supply	V/ph/Hz	230/1/50	230/1/50	230/1/50	400/3/50	400/3/50	400/3/50
Total maximum input power ⁽¹⁾	kW	5,50	5,80	6,20	5,50	5,80	6,20
Total maximum input current ⁽²⁾	A	25,00	26,00	27,00	10,00	11,00	12,00
Compressor							
Compressor	Type/brand	DC twin rotary/ Mitsubishi	DC twin rotary/ Mitsubishi	DC twin rotary/ Mitsubishi			DC twin rotary/ Mitsubishi
Adjustment	Type	Inverter modulating	Inverter modulating	Inverter modulating			Inverter modulating
Minimum capacity control	%	46	41	40	46	41	40
Refrigerant	Type	R32	R32	R32	R32	R32	R32
GWP	CO ₂ equiv. in t/kg	675	675	675	675	675	675
Refrigerant load	kg	1,75	1,75	1,75	1,75	1,75	1,75
Control box load	CO ₂ equiv. in t	1,18	1,18	1,18	1,18	1,18	1,18
Number of circuits	no.	1	1	1	1	1	1
Hermetically sealed control box (EU reg. 517_2014)	yes / no	yes	yes	yes	yes	yes	yes
Fan							
Fan	Type	DC axial	DC axial	DC axial	DC axial	DC axial	DC axial
Quantity	no.	1	1	1	1	1	1
Maximum air flow rate	m ³ /h	4060	4060	4650	4060	4060	4650

Technical data

Description	UM	HYDRO UNIT M 12	HYDRO UNIT M 14	HYDRO UNIT M 16	HYDRO UNIT M 12T	HYDRO UNIT M 14T	HYDRO UNIT M 16T
Heat exchanger (source side)							
Heat exchanger (source side)	Type	Pipes in copper, fins in aluminium with anti-corrosion treatment	Pipes in copper, fins in aluminium with anti-corrosion treatment	Pipes in copper, fins in aluminium with anti-corrosion treatment	Pipes in copper, fins in aluminium with anti-corrosion treatment	Pipes in copper, fins in aluminium with anti-corrosion treatment	Pipes in copper, fins in aluminium with anti-corrosion treatment
Circulation pump							
Circulation pump	Type	Variable speed centrifuge	Variable speed centrifuge	Variable speed centrifuge	Variable speed centrifuge	Variable speed centrifuge	Variable speed centrifuge
Nominal delivery	m ³ /h	2,08	2,49	2,73	2,08	2,49	2,73
Maximum operating pressure	bar	3	3	3	3	3	3
Maximum input power	kW						
Maximum input current	A						
Expansion tank volume	l	8,00	8,00	8,00	8,00	8,00	8,00
Heat exchanger (system side)							
Heat exchanger (system side)	Type	Plate, in stainless steel	Plate, in stainless steel	Plate, in stainless steel	Plate, in stainless steel	Plate, in stainless steel	Plate, in stainless steel
Total water content	l	4,2	4,2	4,2	4,2	4,2	4,2
Sound data							
Sound output ⁽³⁾	dB(A)	65	65	68	65	65	68
Sound pressure at 1m ⁽⁴⁾	dB(A)	53	53,5	57,5	53,5	54	58
Weight							
Net weight	kg	129	129	129	144	144	144

The performance values comply with Standards UNI EN 14511:2018 and UNI EN 14825:2016. Performance data certified by HP Keymark.

(1) Input power from compressors and from fans and circulator in the maximum operating conditions, with the nominal power supply voltage.

(2) Maximum unit operating current with the nominal power supply voltage.

(3) Sound emission values declared, in accordance with standard EN 12102-1.

(4) Measured in a semi-anechoic chamber, at a distance of 1m from the front of the unit and a height from the floor equal to $(1+H)/2$, where H is the height of the unit expressed in metres.

Technical data

HYDRO UNIT M 4-10 ERP technical data

Description	UM	HYDRO UNIT M 4	HYDRO UNIT M 6	HYDRO UNIT M 8	HYDRO UNIT M 10
Temperate zone - Low temperature (30/35°C) EU reg. 811_2013					
Seasonal energy efficiency	%	191	195	205	205
SCOP		4,85	4,95	5,21	5,19
Prated	kW	5,52	6,82	8,12	9,17
Energy class		A+++	A+++	A+++	A+++
Sound output	dB(A)	55	58	59	60
Temperate zone - Medium temperature (47/55°C) Reg. UE 811_2013					
Seasonal energy efficiency	%	130	138	132	137
SCOP		3,31	3,52	3,36	3,49
Prated	kW	4,40	5,70	6,60	7,67
Energy class		A++	A++	A++	A++

NOTE: The performance values comply with Standards: EN 14511 - EN 14825.

HYDRO UNIT M 12-16T ERP technical data

Description	UM	HYDRO UNIT M 12	HYDRO UNIT M 14	HYDRO UNIT M 16	HYDRO UNIT M 12T	HYDRO UNIT M 14T	HYDRO UNIT M 16T
Temperate zone - Low temperature (30/35°C) EU reg. 811_2013							
Seasonal energy efficiency	%	189	186	182	189	186	182
SCOP		4,81	4,72	4,62	4,81	4,72	4,62
Prated	kW	12,00	13,73	15,21	12,00	13,73	15,21
Energy class		A+++	A+++	A+++	A+++	A+++	A+++
Sound output	dB(A)	65	65	68	65	65	68
Temperate zone - Medium temperature (47/55°C) Reg. UE 811_2013							
Seasonal energy efficiency	%	135	136	133	135	136	134
SCOP		3,45	3,47	3,41	3,45	3,47	3,41
Prated	kW	11,58	12,08	13,02	11,58	12,08	13,02
Energy class		A++	A++	A++	A++	A++	A++

NOTE: The performance values comply with Standards: EN 14511 - EN 14825.

Technical data

Performance values in accordance with standards EN 14511:2018 and EN 14825:2016.

HYDRO UNIT M 4 - HEATING

Performance with full load						
Delivery temperature	35°C		45°C		55°C	
Outdoor temperature	Nominal capacity (kW)	COP	Nominal capacity (kW)	COP	Nominal capacity (kW)	COP
-7	4,70	3,10	4,30	2,35	4,00	1,95
2	4,40	4,00	5,10	3,00	5,10	2,45
7	4,20	5,10	4,30	3,80	4,40	2,95
12	5,26	5,61	5,59	4,22	4,98	3,38
15	5,14	4,84	5,67	4,37	4,96	3,53
20	5,09	5,46	5,63	4,88	4,89	3,84
35	5,54	7,89	5,70	6,47	5,14	4,92
Performance with partial load						
Tbival (-7°C)	A	B	C	D	-	-
Outdoor temperature (°C)	-7	2	7	12	-	-
PLR - Climate load factor	0,88	0,54	0,35	0,15	-	-
DC - Output with full load	4,70	4,40	4,20	5,26	-	-
COP with full load	3,10	4,00	5,10	5,61	-	-
COP with partial load	3,12	4,12	4,50	4,04	-	-
CR - Load factor	1,00	0,68	0,46	0,16	-	-
f COP - Corrective factor	1,00	1,03	0,88	0,72	-	-

NOTE: the performance values with a partial load refer to an output water temperature of 35°C.

HYDRO UNIT M 4 - COOLING

	Load factor	Outdoor temperature (°C)	EER	cooling output (kW)
EER1	100%	35	3,45	4,70
EER2	75%	30	4,76	3,53
EER3	50%	25	5,72	2,35
EER4	25%	20	5,72	1,18

HYDRO UNIT M 6 - HEATING

Performance with full load						
Delivery temperature	35°C		45°C		55°C	
Outdoor temperature	Nominal capacity (kW)	COP	Nominal capacity (kW)	COP	Nominal capacity (kW)	COP
-7	6,00	3,00	5,40	2,40	5,15	2,00
2	5,50	3,90	5,80	3,00	5,65	2,45
7	6,35	4,95	6,30	3,70	6,00	2,95
12	6,51	5,38	6,83	4,09	6,12	3,27
15	6,48	5,57	6,98	4,32	6,15	3,42
20	6,27	6,28	6,82	4,62	6,03	3,76
35	6,46	8,87	6,55	5,79	6,02	4,75
Performance with partial load						
Tbival (-7°C)	A	B	C	D	-	-
Outdoor temperature (°C)	-7	2	7	12	-	-
PLR - Climate load factor	0,88	0,54	0,35	0,15	-	-
DC - Output with full load	6,00	5,50	6,35	6,51	-	-
COP with full load	3,00	3,90	4,95	5,38	-	-
COP with partial load	3,03	4,18	4,86	4,09	-	-
CR - Load factor	1,00	0,67	0,38	0,16	-	-
f COP - Corrective factor	1,00	1,07	0,98	0,76	-	-

NOTE: the performance values with a partial load refer to an output water temperature of 35°C.

HYDRO UNIT M 6 - COOLING

	Load factor	Outdoor temperature (°C)	EER	cooling output (kW)
EER1	100%	35	3,00	7,00
EER2	75%	30	4,00	5,25
EER3	50%	25	6,45	3,50
EER4	25%	20	7,73	1,75

Technical data

HYDRO UNIT M 8 - HEATING

Delivery temperature	Performance with full load					
	35°C		45°C		55°C	
	Nominal capacity (kW)	COP	Nominal capacity (kW)	COP	Nominal capacity (kW)	COP
Outdoor temperature						
-7	7,00	3,20	6,60	2,55	6,15	2,05
2	7,10	4,10	7,40	3,25	7,10	2,60
7	8,40	5,15	8,10	3,85	7,50	3,18
12	8,03	5,99	8,06	4,26	7,26	3,54
15	8,11	6,37	8,15	4,55	7,33	3,68
20	8,37	7,53	8,36	5,25	7,47	4,14
35	7,89	8,74	8,83	6,77	7,48	5,03
	Performance with partial load					
Tbival (-7°C)	A	B	C	D	-	-
Outdoor temperature (°C)	-7	2	7	12	-	-
PLR - Climate load factor	0,88	0,54	0,35	0,15	-	-
DC - Output with full load	7,00	7,10	8,40	8,03	-	-
COP with full load	3,20	4,10	5,15	5,99	-	-
COP with partial load	3,28	4,39	5,00	4,37	-	-
CR - Load factor	1,00	0,62	0,34	0,15	-	-
f COP - Corrective factor	1,00	1,07	0,97	0,73	-	-

NOTE: the performance values with a partial load refer to an output water temperature of 35°C.

HYDRO UNIT M 8 - COOLING

	Load factor	Outdoor temperature (°C)	EER	cooling output (kW)
EER1	100%	35	3,39	7,45
EER2	75%	30	4,71	5,59
EER3	50%	25	6,65	3,73
EER4	25%	20	8,55	1,86

HYDRO UNIT M 10 - HEATING

Delivery temperature	Performance with full load					
	35°C		45°C		55°C	
	Nominal capacity (kW)	COP	Nominal capacity (kW)	COP	Nominal capacity (kW)	COP
Outdoor temperature						
-7	8,00	3,05	7,35	2,55	6,85	2,00
2	8,20	4,00	7,85	3,20	8,10	2,56
7	10,00	4,95	10,00	3,75	9,50	3,10
12	9,03	5,77	9,11	4,06	8,50	3,41
15	9,13	6,22	9,22	4,38	8,60	3,67
20	9,58	7,14	9,46	5,08	8,73	4,05
35	8,59	9,01	9,81	6,84	8,63	5,29
	Performance with partial load					
Tbival (-7°C)	A	B	C	D	-	-
Outdoor temperature (°C)	-7	2	7	12	-	-
PLR - Climate load factor	0,88	0,54	0,35	0,15	-	-
DC - Output with full load	8,00	8,20	10,00	9,03	-	-
COP with full load	3,05	4,00	4,95	5,77	-	-
COP with partial load	3,16	4,32	5,19	4,55	-	-
CR - Load factor	1,00	0,60	0,32	0,15	-	-
f COP - Corrective factor	1,00	1,08	1,05	0,79	-	-

NOTE: the performance values with a partial load refer to an output water temperature of 35°C.

HYDRO UNIT M 10 - COOLING

	Load factor	Outdoor temperature (°C)	EER	cooling output (kW)
EER1	100%	35	3,21	8,20
EER2	75%	30	4,47	6,15
EER3	50%	25	7,02	4,10
EER4	25%	20	9,54	2,05

Technical data

HYDRO UNIT M 12 - HEATING

Delivery temperature	Performance with full load					
	35°C		45°C		55°C	
Outdoor temperature	Nominal capacity (kW)	COP	Nominal capacity (kW)	COP	Nominal capacity (kW)	COP
-7	10,00	3,00	10,20	2,40	9,80	2,05
2	9,20	3,90	10,60	3,00	11,30	2,50
7	12,10	4,95	12,30	3,70	11,90	3,05
12	10,98	5,75	11,10	4,26	9,53	3,17
15	11,00	5,97	11,20	4,52	9,12	3,20
20	10,80	7,18	11,20	5,16	9,00	3,61
35	11,50	8,78	11,50	6,17	10,00	4,86
Performance with partial load						
Tbival (-7°C)	A	B	C	D	-	-
Outdoor temperature (°C)	-7	2	7	12	-	-
PLR - Climate load factor	0,88	0,54	0,35	0,15	-	-
DC - Output with full load	10,00	9,20	12,10	10,98	-	-
COP with full load	3,00	3,90	4,95	5,75	-	-
COP with partial load	2,82	4,01	4,85	4,14	-	-
CR - Load factor	1,00	0,70	0,35	0,16	-	-
f COP - Corrective factor	1,00	1,03	0,98	0,72	-	-

NOTE: the performance values with a partial load refer to an output water temperature of 35°C.

HYDRO UNIT M 12 - COOLING

	Load factor	Outdoor temperature (°C)	EER	cooling output (kW)
EER1	100%	35	2,61	11,50
EER2	75%	30	3,93	8,63
EER3	50%	25	5,73	5,75
EER4	25%	20	6,75	2,88

HYDRO UNIT M 14 - HEATING

Delivery temperature	Performance with full load					
	35°C		45°C		55°C	
Outdoor temperature	Nominal capacity (kW)	COP	Nominal capacity (kW)	COP	Nominal capacity (kW)	COP
-7	12,00	2,85	11,80	2,35	11,00	2,05
2	11,00	3,60	11,50	2,85	12,40	2,45
7	14,50	4,60	14,10	3,60	13,80	2,95
12	11,51	5,46	11,69	4,12	10,28	3,32
15	11,60	5,67	11,90	4,25	9,84	3,41
20	11,10	6,27	11,50	4,87	9,53	3,74
35	11,80	8,63	12,00	6,10	10,10	4,93
Performance with partial load						
Tbival (-7°C)	A	B	C	D	-	-
Outdoor temperature (°C)	-7	2	7	12	-	-
PLR - Climate load factor	0,88	0,54	0,35	0,15	-	-
DC - Output with full load	12,00	11,00	14,50	11,51	-	-
COP with full load	2,85	3,60	4,60	5,46	-	-
COP with partial load	2,73	3,90	4,90	4,26	-	-
CR - Load factor	1,00	0,67	0,33	0,18	-	-
f COP - Corrective factor	1,00	1,08	1,06	0,78	-	-

NOTE: the performance values with a partial load refer to an output water temperature of 35°C.

HYDRO UNIT M 14 - COOLING

	Load factor	Outdoor temperature (°C)	EER	cooling output (kW)
EER1	100%	35	2,50	12,40
EER2	75%	30	3,85	9,30
EER3	50%	25	5,80	6,20
EER4	25%	20	6,74	3,10

Technical data

HYDRO UNIT M 16 - HEATING

Delivery temperature	Performance with full load					
	35°C		45°C		55°C	
Outdoor temperature	Nominal capacity (kW)	COP	Nominal capacity (kW)	COP	Nominal capacity (kW)	COP
-7	13,10	2,70	12,80	2,25	12,50	2,00
2	13,00	3,45	12,70	2,85	13,30	2,40
7	15,90	4,50	16,00	3,50	16,00	2,85
12	14,03	5,58	13,76	4,22	12,69	3,44
15	14,50	5,97	14,20	4,46	13,20	3,61
20	12,70	6,88	12,20	4,71	11,20	3,68
35	12,80	9,06	12,50	6,02	10,40	4,57
Performance with partial load						
Tbival (-7°C)	A	B	C	D	-	-
Outdoor temperature (°C)	-7	2	7	12	-	-
PLR - Climate load factor	0,88	0,54	0,35	0,15	-	-
DC - Output with full load	13,10	13,00	15,90	14,03	-	-
COP with full load	2,70	3,45	4,50	5,58	-	-
COP with partial load	2,66	3,80	4,81	4,32	-	-
CR - Load factor	1,00	0,63	0,33	0,16	-	-
f COP - Corrective factor	1,00	1,10	1,07	0,77	-	-

NOTE: the performance values with a partial load refer to an output water temperature of 35°C.

HYDRO UNIT M 16 - COOLING

	Load factor	Outdoor temperature (°C)	EER	cooling output (kW)
EER1	100%	35	2,47	14,00
EER2	75%	30	3,63	10,50
EER3	50%	25	5,27	7,00
EER4	25%	20	7,29	3,50

HYDRO UNIT M 12T - HEATING

Delivery temperature	Performance with full load					
	35°C		45°C		55°C	
Outdoor temperature	Nominal capacity (kW)	COP	Nominal capacity (kW)	COP	Nominal capacity (kW)	COP
-7	10,00	3,00	10,20	2,40	9,80	2,05
2	9,20	3,90	10,60	3,00	11,30	2,50
7	12,10	4,95	12,30	3,70	11,90	3,05
12	10,98	5,75	11,10	4,26	9,53	3,17
15	11,00	5,97	11,20	4,52	9,12	3,20
20	10,80	7,18	11,20	5,16	9,00	3,61
35	11,50	8,78	11,50	6,17	10,00	4,86
Performance with partial load						
Tbival (-7°C)	A	B	C	D	-	-
Outdoor temperature (°C)	-7	2	7	12	-	-
PLR - Climate load factor	0,88	0,54	0,35	0,15	-	-
DC - Output with full load	10,00	9,20	12,10	10,98	-	-
COP with full load	3,00	3,90	4,95	5,75	-	-
COP with partial load	2,82	4,01	4,85	4,14	-	-
CR - Load factor	1,00	0,70	0,35	0,16	-	-
f COP - Corrective factor	1,00	1,03	0,98	0,72	-	-

NOTE: the performance values with a partial load refer to an output water temperature of 35°C.

HYDRO UNIT M 12T - COOLING

	Load factor	Outdoor temperature (°C)	EER	cooling output (kW)
EER1	100%	35	2,61	11,50
EER2	75%	30	3,93	8,63
EER3	50%	25	5,73	5,75
EER4	25%	20	6,75	2,88

Technical data

HYDRO UNIT M 14T - HEATING

Delivery temperature	Performance with full load					
	35°C		45°C		55°C	
Outdoor temperature	Nominal capacity (kW)	COP	Nominal capacity (kW)	COP	Nominal capacity (kW)	COP
-7	12,00	2,85	11,80	2,35	11,00	2,05
2	11,00	3,60	11,50	2,85	12,40	2,45
7	14,50	4,60	14,10	3,60	13,80	2,95
12	11,51	5,46	11,69	4,12	10,28	3,32
15	11,60	5,67	11,90	4,25	9,84	3,41
20	11,10	6,27	11,50	4,87	9,53	3,74
35	11,80	8,63	12,00	6,10	10,10	4,93
Performance with partial load						
Tbival (-7°C)	A	B	C	D	-	-
Outdoor temperature (°C)	-7	2	7	12	-	-
PLR - Climate load factor	0,88	0,54	0,35	0,15	-	-
DC - Output with full load	12,00	11,00	14,50	11,51	-	-
COP with full load	2,85	3,60	4,60	5,46	-	-
COP with partial load	2,73	3,90	4,90	4,26	-	-
CR - Load factor	1,00	0,67	0,33	0,18	-	-
f COP - Corrective factor	1,00	1,08	1,06	0,78	-	-

NOTE: the performance values with a partial load refer to an output water temperature of 35°C.

HYDRO UNIT M 14T - COOLING

	Load factor	Outdoor temperature (°C)	EER	cooling output (kW)
EER1	100%	35	2,46	12,40
EER2	75%	30	3,85	9,30
EER3	50%	25	5,80	6,20
EER4	25%	20	6,74	3,10

HYDRO UNIT M 16T - HEATING

Delivery temperature	Performance with full load					
	35°C		45°C		55°C	
Outdoor temperature	Nominal capacity (kW)	COP	Nominal capacity (kW)	COP	Nominal capacity (kW)	COP
-7	13,10	2,70	12,80	2,25	12,50	2,00
2	13,00	3,45	12,70	2,85	13,30	2,40
7	15,90	4,50	16,00	3,50	16,00	2,85
12	14,03	5,58	13,76	4,22	12,69	3,44
15	14,50	5,97	14,20	4,46	13,20	3,61
20	12,70	6,88	12,20	4,71	11,20	3,68
35	12,80	9,06	12,50	6,02	10,40	4,57
Performance with partial load						
Tbival (-7°C)	A	B	C	D	-	-
Outdoor temperature (°C)	-7	2	7	12	-	-
PLR - Climate load factor	0,88	0,54	0,35	0,15	-	-
DC - Output with full load	13,10	13,00	15,90	14,03	-	-
COP with full load	2,70	3,45	4,50	5,58	-	-
COP with partial load	2,66	3,80	4,81	4,32	-	-
CR - Load factor	1,00	0,63	0,33	0,16	-	-
f COP - Corrective factor	1,00	1,10	1,07	0,77	-	-

NOTE: the performance values with a partial load refer to an output water temperature of 35°C.

HYDRO UNIT M 16T - COOLING

	Load factor	Outdoor temperature (°C)	EER	cooling output (kW)
EER1	100%	35	2,47	14,00
EER2	75%	30	3,63	10,50
EER3	50%	25	5,27	7,00
EER4	25%	20	7,29	3,50

Technical data

Flow rate-pressure drop diagrams

HYDRO UNIT M is equipped with a variable speed circulation pump.
 When dimensioning the system, consider the residual head, shown in the diagrams below.

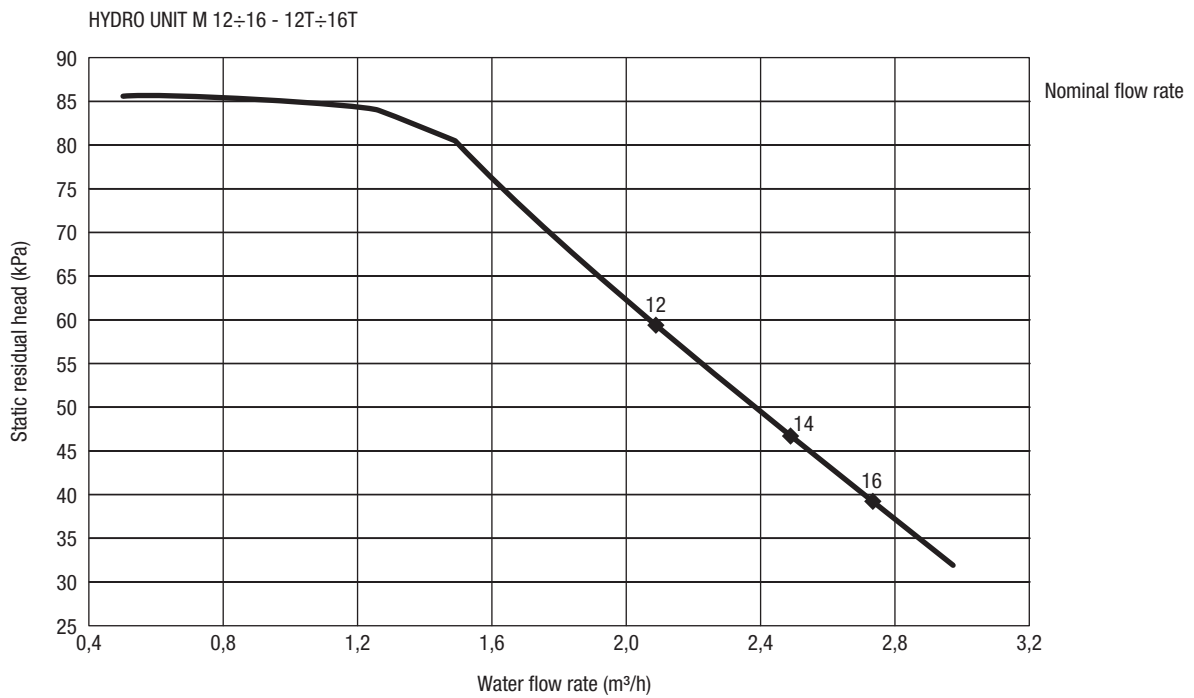
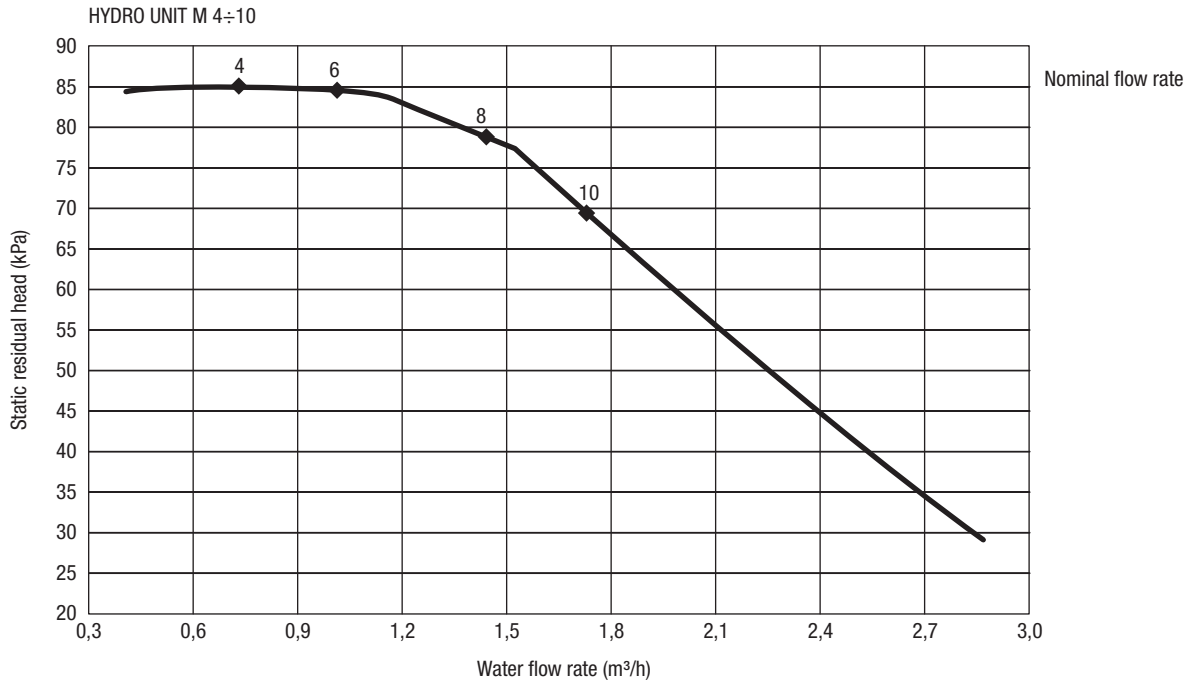

Model	UM	HYDRO UNIT M									
		4	6	8	10	12	14	16	12T	14T	16T
Useful pump head (A7; W35) (1)	kPa	85	84	78	69	59	47	39	59	47	39

(1) Outdoor air temperature 7°C BS, 6°C BU; 30/35°C water inlet/outlet.

Technical data

Technical characteristics

HYDRO UNIT M 4	
Power Supply	230/1/50V/ph/Hz
Dimensions (H×W×D):	approx. 1295×792×429 mm
Heating	
SCOP	4.85 (medium climate, low temperature)
Class	A+++
Heating capacity (A7/W35)	4,20 kW
Input power (A7/W35)	0,82 kW
COP (A7/W35)	5,10
Outside air temperature operating range	-25°C - +35°C
Water delivery temperature operating range	+12°C - +65°C
Sound output	55 dB(A)
Cooling	
Cooling capacity (A35/W7)	4,70 kW
Input power (A35/W7)	1,36 kW
EER (A35/W7)	3,45
Outside air temperature operating range	-5°C - +43°C
Water delivery temperature operating range	+5°C - +25°C
Sound output	55 dB(A)
HYDRO UNIT M 6	
Power Supply	230/1/50V/ph/Hz
Dimensions (H×W×D):	approx. 1295×792×429 mm
Heating	
SCOP	4,95 (medium climate, low temperature)
Class	A+++
Heating capacity (A7/W35)	6,35 kW
Input power (A7/W35)	1,28 kW
COP (A7/W35)	4,95
Outside air temperature operating range	-25°C - +35°C
Water delivery temperature operating range	+12°C - +65°C
Sound output	58 dB(A)
Cooling	
Cooling capacity (A35/W7)	7,00 kW
Input power (A35/W7)	2,33 kW
EER (A35/W7)	3,00
Outside air temperature operating range	-5°C - +43°C
Water delivery temperature operating range	+5°C - +25°C
Sound output	58 dB(A)

Technical data

HYDRO UNIT M 8	
Power Supply	230/1/50V/ph/Hz
Dimensions (H×W×D):	approx. 1385×945×526 mm
Heating	
SCOP	5,22 (medium climate, low temperature)
Class	A+++
Heating capacity (A7/W35)	8,40 kW
Input power (A7/W35)	1,63 kW
COP (A7/W35)	5,15
Outside air temperature operating range	-25°C - +35°C
Water delivery temperature operating range	+12°C - +65°C
Sound output	59 dB(A)
Cooling	
Cooling capacity (A35/W7)	7,45 kW
Input power (A35/W7)	2,22 kW
EER (A35/W7)	3,35
Outside air temperature operating range	-5°C - +43°C
Water delivery temperature operating range	+5°C - +25°C
Sound output	59 dB(A)

HYDRO UNIT M 10	
Power Supply	230/1/50V/ph/Hz
Dimensions (H×W×D):	approx. 1385×945×526 mm
Heating	
SCOP	5,20 (medium climate, low temperature)
Class	A+++
Heating capacity (A7/W35)	10,00 kW
Input power (A7/W35)	2,02 kW
COP (A7/W35)	4,95
Outside air temperature operating range	-25°C - +35°C
Water delivery temperature operating range	+12°C - +65°C
Sound output	60 dB(A)
Cooling	
Cooling capacity (A35/W7)	8,20 kW
Input power (A35/W7)	2,52 kW
EER (A35/W7)	3,25
Outside air temperature operating range	-5°C - +43°C
Water delivery temperature operating range	+5°C - +25°C
Sound output	60 dB(A)

Technical data

HYDRO UNIT M 12	
Power Supply	230/1/50V/ph/Hz
Dimensions (H×W×D):	approx. 1385×945×526 mm
Heating	
SCOP	4,81 (medium climate, low temperature)
Class	A+++
Heating capacity (A7/W35)	12,10 kW
Input power (A7/W35)	2,44 kW
COP (A7/W35)	4,95
Outside air temperature operating range	-25°C - +35°C
Water delivery temperature operating range	+12°C - +65°C
Sound output	65 dB(A)
Cooling	
Cooling capacity (A35/W7)	11,50 kW
Input power (A35/W7)	4,18 kW
EER (A35/W7)	2,75
Outside air temperature operating range	-5°C - +43°C
Water delivery temperature operating range	+5°C - +25°C
Sound output	65 dB(A)

HYDRO UNIT M 14	
Power Supply	230/1/50V/ph/Hz
Dimensions (H×W×D):	approx. 1385×945×526 mm
Heating	
SCOP	4,72 (medium climate, low temperature)
Class	A+++
Heating capacity (A7/W35)	14,50 kW
Input power (A7/W35)	3,15 kW
COP (A7/W35)	4,60
Outside air temperature operating range	-25°C - +35°C
Water delivery temperature operating range	+12°C - +65°C
Sound output	65 dB(A)
Cooling	
Cooling capacity (A35/W7)	12,40 kW
Input power (A35/W7)	4,96 kW
EER (A35/W7)	2,50
Outside air temperature operating range	-5°C - +43°C
Water delivery temperature operating range	+5°C - +25°C
Sound output	65 dB(A)

Technical data

HYDRO UNIT M 16	
Power Supply	230/1/50V/ph/Hz
Dimensions (H×W×D):	approx. 1385×945×526 mm
Heating	
SCOP	4,62 (medium climate, low temperature)
Class	A+++
Heating capacity (A7/W35)	15,90 kW
Input power (A7/W35)	3,53 kW
COP (A7/W35)	4,50
Outside air temperature operating range	-25°C - +35°C
Water delivery temperature operating range	+12°C - +65°C
Sound output	68 dB(A)
Cooling	
Cooling capacity (A35/W7)	14,00 kW
Input power (A35/W7)	5,60 kW
EER (A35/W7)	2,50
Outside air temperature operating range	-5°C - +43°C
Water delivery temperature operating range	+5°C - +25°C
Sound output	68 dB(A)
HYDRO UNIT M 12T	
Power Supply	230/1/50V/ph/Hz
Dimensions (H×W×D):	approx. 1385×945×526 mm
Heating	
SCOP	4,81 (medium climate, low temperature)
Class	A+++
Heating capacity (A7/W35)	12,10 kW
Input power (A7/W35)	2,44 kW
COP (A7/W35)	4,95
Outside air temperature operating range	-25°C - +35°C
Water delivery temperature operating range	+12°C - +65°C
Sound output	65 dB(A)
Cooling	
Cooling capacity (A35/W7)	11,50 kW
Input power (A35/W7)	4,18 kW
EER (A35/W7)	2,75
Outside air temperature operating range	-5°C - +43°C
Water delivery temperature operating range	+5°C - +25°C
Sound output	65 dB(A)

Technical data

HYDRO UNIT M 14T	
Power Supply	230/1/50V/ph/Hz
Dimensions (H×W×D):	approx. 1385×945×526 mm
Heating	
SCOP	4,72 (medium climate, low temperature)
Class	A+++
Heating capacity (A7/W35)	14,50 kW
Input power (A7/W35)	3,15 kW
COP (A7/W35)	4,60
Outside air temperature operating range	-25°C - +35°C
Water delivery temperature operating range	+12°C - +65°C
Sound output	65 dB(A)
Cooling	
Cooling capacity (A35/W7)	12,40 kW
Input power (A35/W7)	4,96 kW
EER (A35/W7)	2,50
Outside air temperature operating range	-5°C - +43°C
Water delivery temperature operating range	+5°C - +25°C
Sound output	65 dB(A)

HYDRO UNIT M 16T	
Power Supply	230/1/50V/ph/Hz
Dimensions (H×W×D):	approx. 1385×945×526 mm
Heating	
SCOP	4,62 (medium climate, low temperature)
Class	A+++
Heating capacity (A7/W35)	15,90 kW
Input power (A7/W35)	3,53 kW
COP (A7/W35)	4,50
Outside air temperature operating range	-25°C - +35°C
Water delivery temperature operating range	+12°C - +65°C
Sound output	68 dB(A)
Cooling	
Cooling capacity (A35/W7)	14,00 kW
Input power (A35/W7)	5,60 kW
EER (A35/W7)	2,50
Outside air temperature operating range	-5°C - +43°C
Water delivery temperature operating range	+5°C - +25°C
Sound output	68 dB(A)

Operating range

Outlet water (heating mode)	+12 ~ +65°C	
Outlet water (cooling mode)	+5 ~ +25°C	
Domestic hot water	+12 ~ +60°C	
Ambient temperature	-25 ~ +43°C	
Water pressure	0,1~0,3 MPa(g)	
Water flow rate	4kW	0,40~0,90 m³/h
	6kW	0,40~1,25 m³/h
	8kW	0,40~1,65 m³/h
	10kW	0,40~2,10 m³/h
	12kW	0,70~2,50 m³/h
	14kW	0,70~2,75 m³/h
	16kW	0,70~3,00 m³/h

The unit has an anti-freeze function that uses the heat pump or backup heater (personalised model) to protect the water system from freezing in all conditions. There is always the risk that a power blackout may occur when the unit is unsupervised, so you are advised to use the anti-freeze flow switch in the water system.

The temperature ranges of the flowing water (TW_outlet) in cooling mode, with various outdoor temperatures (T4), are shown below:

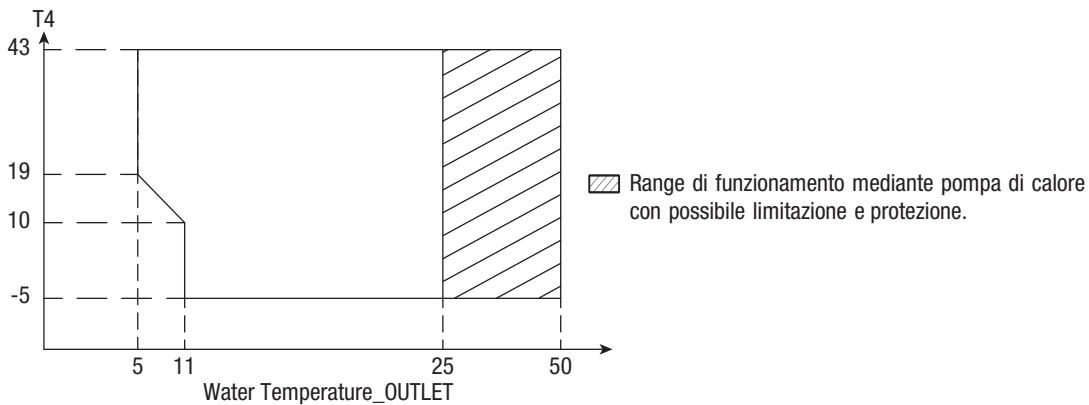

The temperature ranges of the flowing water (TW_outlet) in heating mode, with various ambient temperatures (T4), are shown below:

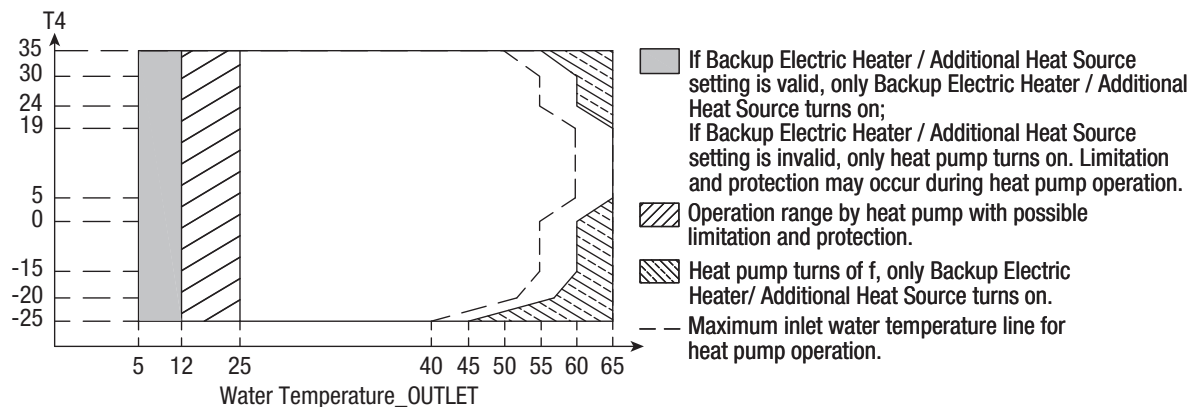

Operating range

The temperature ranges of the flowing water (TW_outlet) in DHW mode, with various ambient temperatures (T4), are shown below:

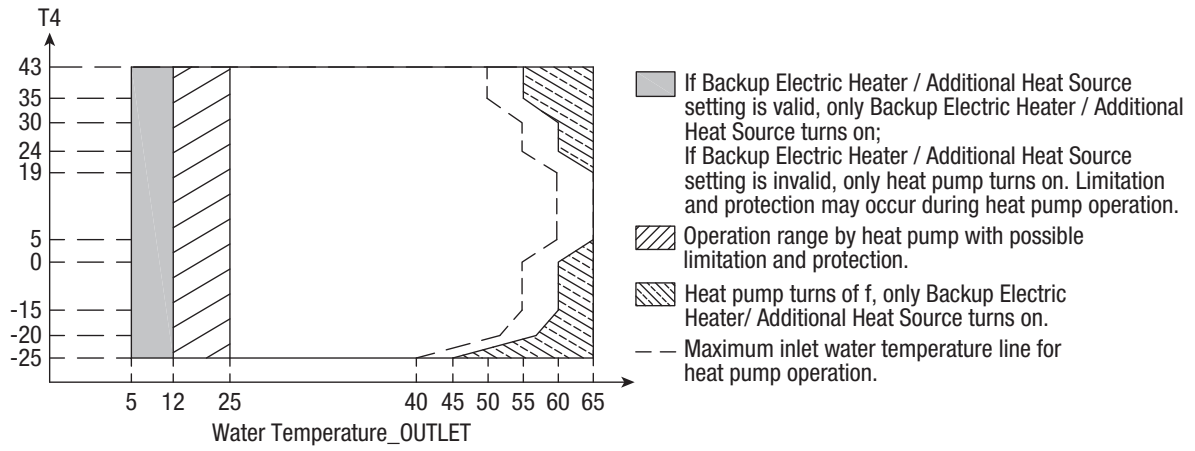

Description and use of the appliance

Overall dimensions

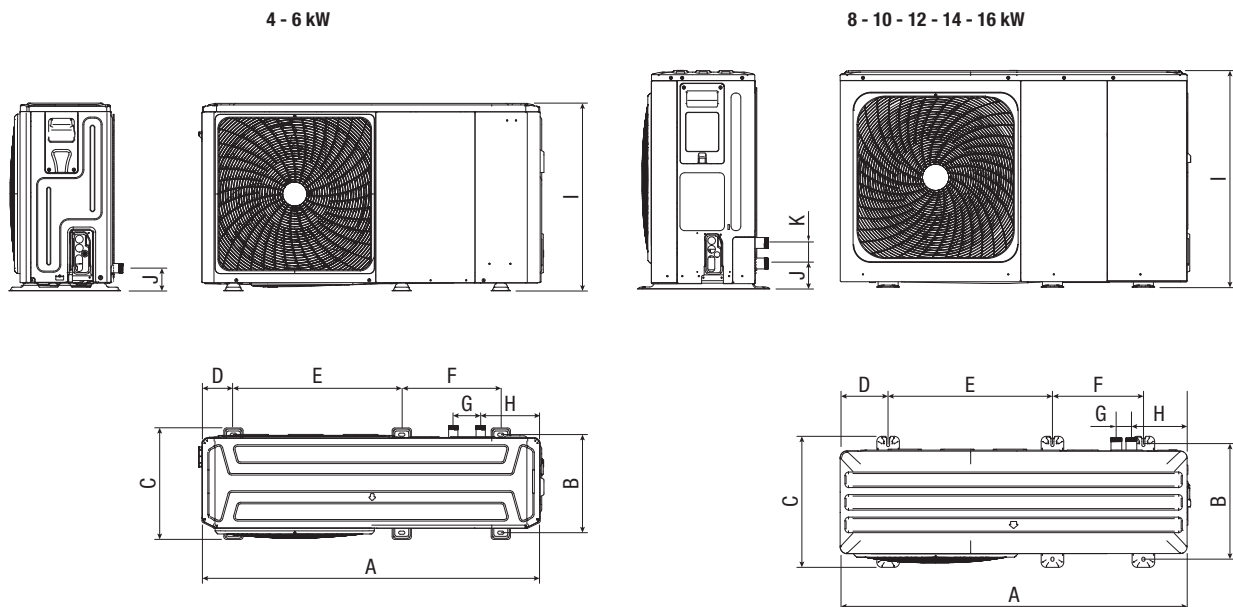

Model	A	B	C	D	E	F	G	H	I	J	K
4-6 kW	1295	375	426	120	644	379	105	225	718	87	/
8-10-12-14-16 kW	1385	458	523	192	656	363	60	221	865	101	81

Units expressed in millimetres

Description and use of the appliance

Hydraulic connections

4÷6 kW

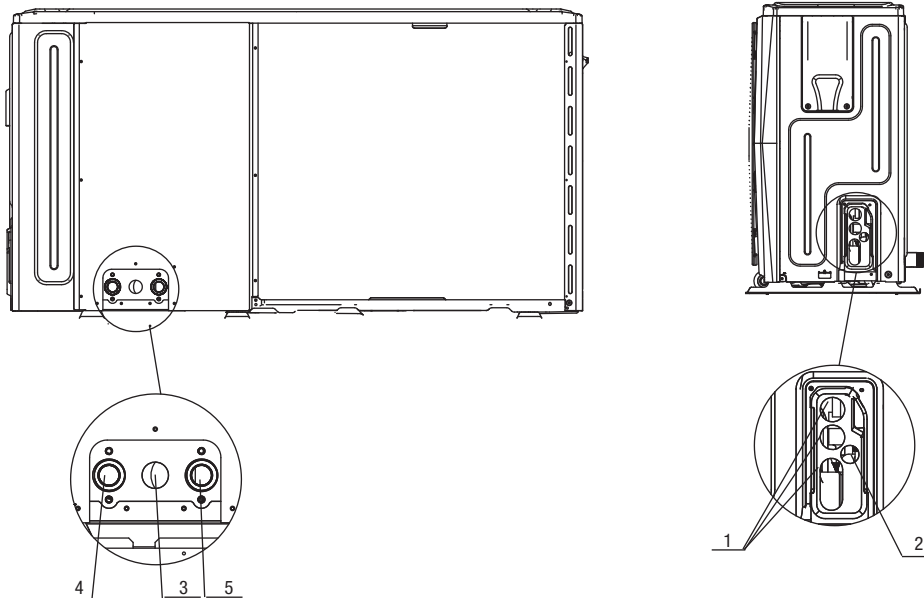

8÷16 kW

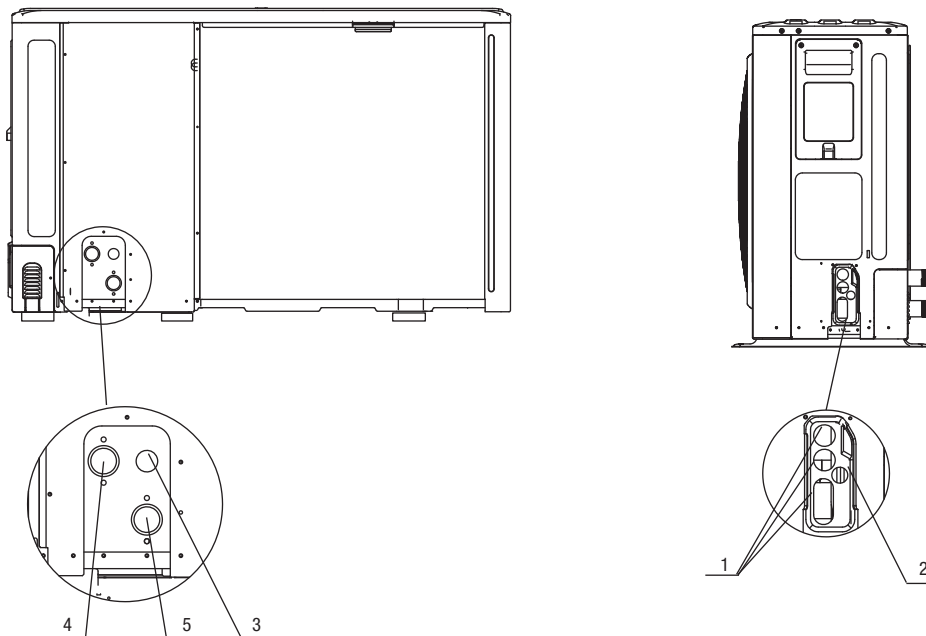

1	High voltage cable routing
2	Low voltage cable routing
3	Hole for safety valve discharge pipe
4	System delivery connection (*)
5	System return connection (*)

(*) R1" (4÷6 kW), R1"¼ (8÷16 kW) diameter.

Description and use of the appliance

Technical characteristics

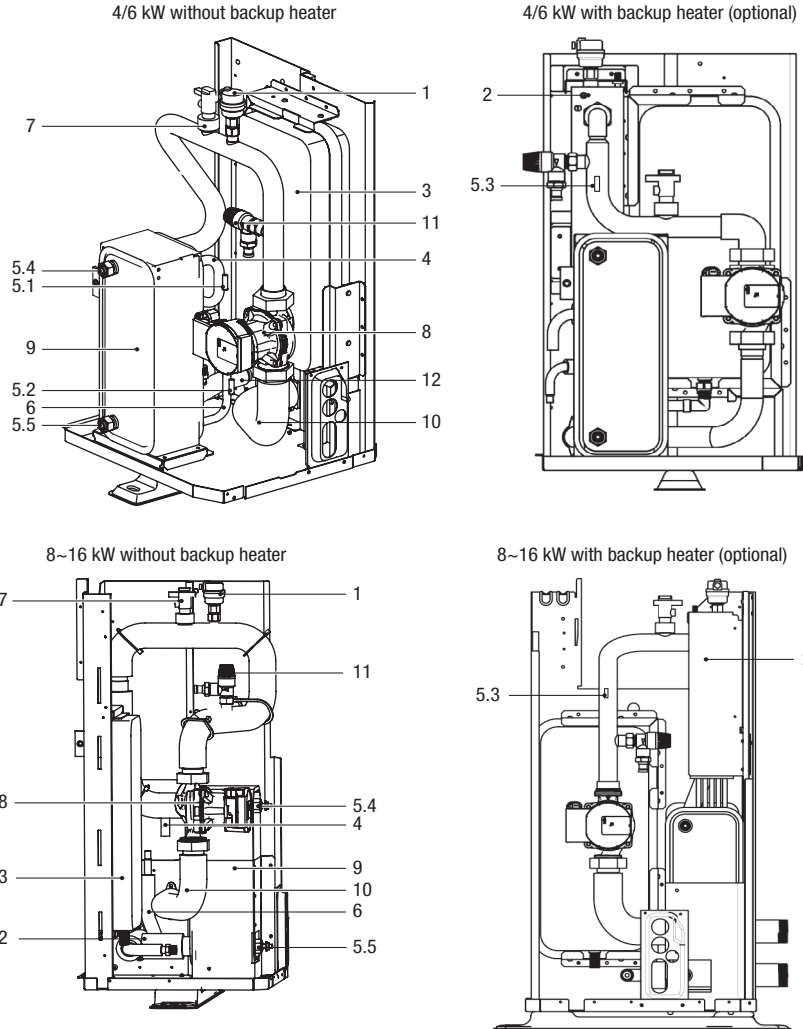

Code	Assembly unit	Explanation
1	Air purge valve	The residual air in the water circuit is automatically removed.
2	Backup heater (optional)	Provides additional heating capacity when that of the heat pump is insufficient due to very low outdoor temperatures. Also protects the outdoor water piping from freezing.
3	Expansion tank	Balances the water system pressure.
4	Refrigerant gas pipe	/
5	Temperature sensors	Four temperature sensors measure the temperature of the water and refrigerant in various points of the water circuit. 5.1-T2B; 5.2-T2; 5.3-T1 (optional); 5.4-TW_out; 5.5-TW_in
6	Liquid refrigerant pipe	/
7	Flow meter	Measures the water flow rate to protect the compressor and water pump in the event of an insufficient water flow.
8	Pump	Enables the water to circulate in the dedicated circuit.
9	Plate heat exchanger	Transfers heat from the refrigerant to the water.
10	Water outlet pipe	/
11	Overpressure valve	Avoids any excessive water pressure by opening at 3 bar and draining the water from the dedicated circuit.
12	Water inlet pipe	/

Electric wiring

Precautions for the electricity supply wiring

When making the connection to the power supply terminal board, use a round crimped terminal. If this is impossible, follow the instructions below.

- Do not connect cables of different sizes to the same power supply terminal (loose connections may lead to overheating).
- When connecting cables of the same size, do so as shown below.

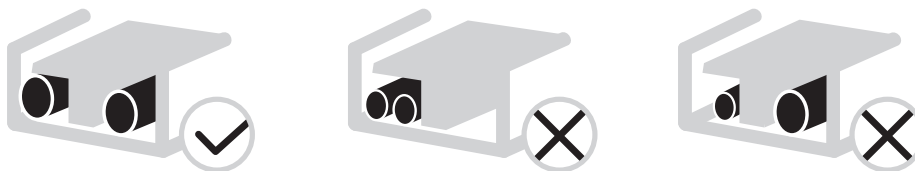

- Use the right screwdriver to tighten the terminal screws; small screwdrivers may damage the head of the screw and prevent it from being properly tightened.
- Do not over-tighten the terminal screws, as this may damage them.
- Connect an earth circuit switch and a fuse to the power supply line.
- Making sure the appropriate wires are used, make the complete connections and fix the wires so that the external force cannot affect the terminals.

Safety device requisites

1. Select the cable diameters (minimum value) individually for each unit on the basis of tables 1 and 2, where the nominal current in table 1 means MCA in table 2. If the MCA is higher than 63A, the wire diameters must be selected in accordance with the national wiring regulations.
2. The maximum permitted variation between the phases in the voltage field is 2%.
3. Select the circuit breaker that separates the contacts by at least 3mm on all the poles and allows for complete disconnection, where the MFA is used to select the current circuit breakers and the residual current circuit breakers.

TABLE 1		
Nominal current of the appliance: (A)	Nominal cross section area (mm ²)	
	Flexible cables	Fixed wiring cable
≤3	0,5 and 0,75	1 and 2,5
>3 and ≤6	0,75 and 1	1 and 2,5
>6 and ≤10	1 and 1,5	1 and 2,5
>10 and ≤16	1,5 and 2,5	1,5 and 4
>16 and ≤25	2,5 and 4	2,5 and 6
>25 and ≤32	4 and 6	4 and 10
>32 and ≤50	6 and 10	6 and 16
>50 and ≤63	10 and 16	10 and 25

Electric wiring

TABLE 2 (Standard 4 - 16 kW single-phase and standard 12 - 16 kW three-phase)											
System	Voltage (V)	Outdoor unit			Supply current			Compressor		OFM	
		Hz	Min. (V)	Max. (V)	MCA (A)	TOCA (A)	MFA (A)	MSC (A)	RLA (A)	KW	FLA (A)
4kW	220-240	50	198	264	12	18	25	-	11,50	0,10	0,50
6kW	220-240	50	198	264	14	18	25	-	13,50	0,10	0,50
8kW	220-240	50	198	264	16	19	25	-	14,50	0,17	1,50
10kW	220-240	50	198	264	17	19	25	-	15,50	0,17	1,50
12kW	220-240	50	198	264	25	30	35	-	23,50	0,17	1,50
14kW	220-240	50	198	264	26	30	35	-	24,50	0,17	1,50
16kW	220-240	50	198	264	27	30	35	-	25,50	0,17	1,50
12 kW three-phase	380-415	50	342	456	10	14	16	-	9,15	0,17	1,50
14 kW three-phase	380-415	50	342	456	11	14	16	-	10,15	0,17	1,50
16 kW three-phase	380-415	50	342	456	12	14	16	-	11,15	0,17	1,50

TABLE 2 (4 - 16 kW single-phase and 12 - 16 kW three-phase standard with 3 kW backup heater)											
System	Voltage (V)	Outdoor unit			Supply current			Compressor		OFM	
		Hz	Min. (V)	Max. (V)	MCA (A)	TOCA (A)	MFA (A)	MSC (A)	RLA (A)	KW	FLA (A)
4kW	220-240	50	198	264	25	31	38	-	11,50	0,10	0,50
6kW	220-240	50	198	264	27	31	38	-	13,50	0,10	0,50
8kW	220-240	50	198	264	29	32	38	-	14,50	0,17	1,50
10kW	220-240	50	198	264	30	32	38	-	15,50	0,17	1,50
12kW	220-240	50	198	264	38	43	48	-	23,50	0,17	1,50
14kW	220-240	50	198	264	39	43	48	-	24,50	0,17	1,50
16kW	220-240	50	198	264	40	43	48	-	25,50	0,17	1,50
12 kW three-phase	380-415	50	342	456	23	27	29	-	9,15	0,17	1,50
14 kW three-phase	380-415	50	342	456	24	27	29	-	10,15	0,17	1,50
16 kW three-phase	380-415	50	342	456	25	27	29	-	11,15	0,17	1,50

TABLE 2 (8 - 16 kW single-phase and 12 - 16 kW three-phase standard with 9 kW backup heater)											
System	Voltage (V)	Outdoor unit			Supply current			Compressor		OFM	
		Hz	Min. (V)	Max. (V)	MCA (A)	TOCA (A)	MFA (A)	MSC (A)	RLA (A)	KW	FLA (A)
8kW	380-415	50	342	456	29	32	38	-	14,50	0,17	1,50
10kW	380-415	50	342	456	30	32	38	-	15,50	0,17	1,50
12kW	380-415	50	342	456	38	43	48	-	23,50	0,17	1,50
14kW	380-415	50	342	456	39	43	48	-	24,50	0,17	1,50
16kW	380-415	50	342	456	40	43	48	-	25,50	0,17	1,50
12 kW three-phase	380-415	50	342	456	23	27	29	-	9,15	0,17	1,50
14 kW three-phase	380-415	50	342	456	24	27	29	-	10,15	0,17	1,50
16 kW three-phase	380-415	50	342	456	25	27	29	-	11,15	0,17	1,50

MCA: Maximum circuit ampacity (A)

TOCA: Total overcurrent amps (A)

MFA: Maximum fuse amps (A)

MSC: Maximum starting current (A)

RLA: In test conditions with nominal cooling or heating, the compressor input amps where MAX. Hz can work with the nominal load amps (A)

KW: Nominal motor output

FLA: Amperage with full load (A).

Electric wiring

Removing the switch box cover

Standard 4 - 16 kW single-phase and standard 12 - 16 kW three-phase

Unit	4kW	6kW	8kW	10kW	12kW	14kW	16kW	12kW Three- phase	14kW Three- phase	16kW Three- phase
Maximum overcurrent protection (MOP) (A)	18	18	19	19	30	30	30	14	14	14
Cable dimensions (mm ²)	4,0	4,0	4,0	4,0	6,0	6,0	6,0	2,5	2,5	2,5

Standard 4 - 16 kW single-phase and 12 - 16 kW three-phase standard with 3 kW backup heater (single-phase)

Unit	4kW	6kW	8kW	10kW	12kW	14kW	16kW	12kW Three- phase	14kW Three- phase	16kW Three- phase
Maximum overcurrent protection (MOP) (A)	31	31	32	32	43	43	43	27	27	27
Cable dimensions (mm ²)	6,0	6,0	8,0	8,0	10,0	10,0	10,0	4,0	4,0	4,0

Standard 8 - 16 kW single-phase and 12 - 16 kW three-phase standard with 9 kW backup heater (three-phase)

Unit	8kW	10kW	12kW	14kW	16kW	12kW Three- phase	14kW Three- phase	16kW Three- phase
Maximum overcurrent protection (MOP) (A)	32	32	43	43	43	27	27	27
Cable dimensions (mm ²)	8,0	8,0	10,0	10,0	10,0	4,0	4,0	4,0

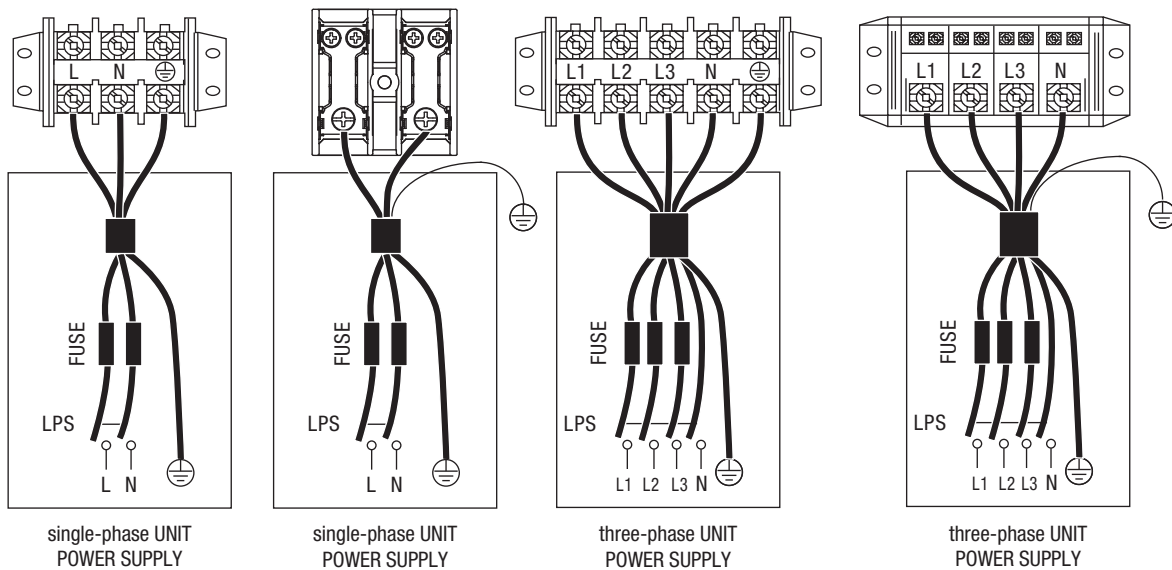

Electric wiring

Connections for other components

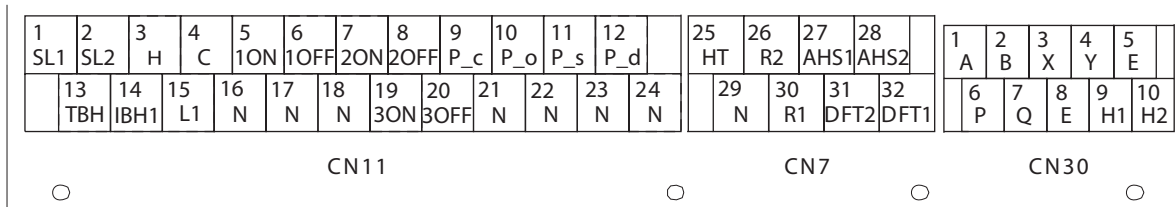

CODE	PRINT	CONNECTION TO
1	1 SL1	Solar energy input signal
	2 SL2	
	3 H	
2	4 C	Room thermostat input (high voltage)
	15 L1	
3	5 10N	SV1 (3-way valve)
	6 10FF	
4	7 20N	SV2 (3-way valve)
	17 N	
5	9 P_c	Pump c (zone 2 pump)
	21 N	
6	10 P_o	External circulation pump (zone 1 pump)
	22 N	
7	11 P_s	Solar energy pump
	23 N	
8	12 P_d	DHW tube pump
	24 N	
9	13 TBH	Tank booster heater
	16 N	
10	14 IBH1	Internal backup heater 1
	17 N	
	18 N	
11	19 30N	SV3 (3-way valve)
	20 30FF	

CODE	PRINT	CONNECTION TO
1	1 E	Wired control panel
	2 P	
	3 Q	
	4 H1	
	5 H2	
2	6 A	Outdoor unit
	7 B	
3	9 X	Internal parallel machine
	10 Y	

CODE	PRINT	CONNECTION TO
1	26 R2	Compressor operation
	30 R1	
	31 DFT2	
2	32 DFT1	Defrosting operation
	25 HT	
	29 N	
3	27 AHS1	Additional heating source
	28 AHS2	

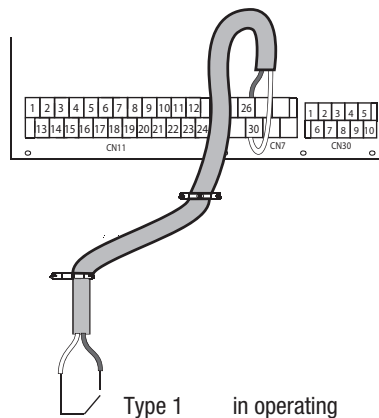

The port supplies the load with the control signal. Two types of control signal port:

Type 1: dry voltage-free connector.

Type 2: the port supplies the signal with a 220V voltage. If the load current is $<0,2\text{ A}$, the load can be connected directly to the port. If the load current is $\geq 0,2\text{ A}$, the AC contactor must be connected for the load.

Typical applications

Application 1

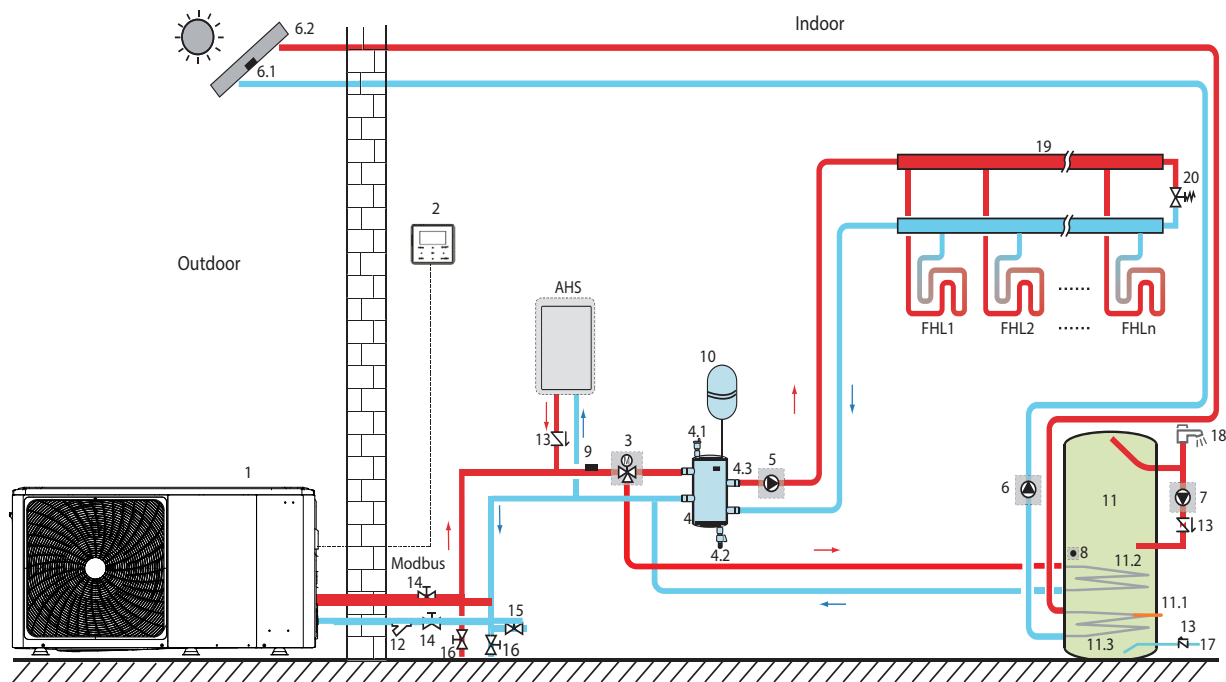

Code	Assembly unit
1	Main unit
2	User interface
3	Sv1: 3-way valve (field power supply)
4	Balancing tank (field power supply)
4.1	Automatic air purge valve
4.2	Drain valve
4.3	Tbt1: Upper temperature sensor of the balancing tank (optional)
4.4	Tbt2: Lower temperature sensor of the balancing tank (optional)
5	P_o: External circulation pump (field power supply)
6	P_s: Solar pump (field power supply)
6.1	Tsolar: Solar temperature sensor (optional)
6.2	Solar panel (field power supply)
7	P_d: Pump for DHW pipes (field power supply)
8	T5: DHW tank temperature sensor (accessory)
9	T1: Total water flow temperature sensor (optional)
10	Expansion tank (field power supply)

11	DHW tank (field power supply)
11.1	TBH: DHW storage tank heater (field power supply)
11.2	Coil 1, heat exchanger for heat pump
11.3	Coil 2, heat exchanger for solar energy
12	Filter (accessory)
13	Control valve (field power supply)
14	Shut-off valve (field power supply)
15	Filler valve (field power supply)
16	Discharge valve (field power supply)
17	Tap water inlet pipe (field power supply)
18	Hot water tap (field power supply)
19	Manifold/distributor (field power supply)
20	Bypass valve (field power supply)
FHL 1... n	Floor heating circuit (field power supply)
AHS	Auxiliary heat source (field power supply)

Typical applications

Application 2 - One zone control

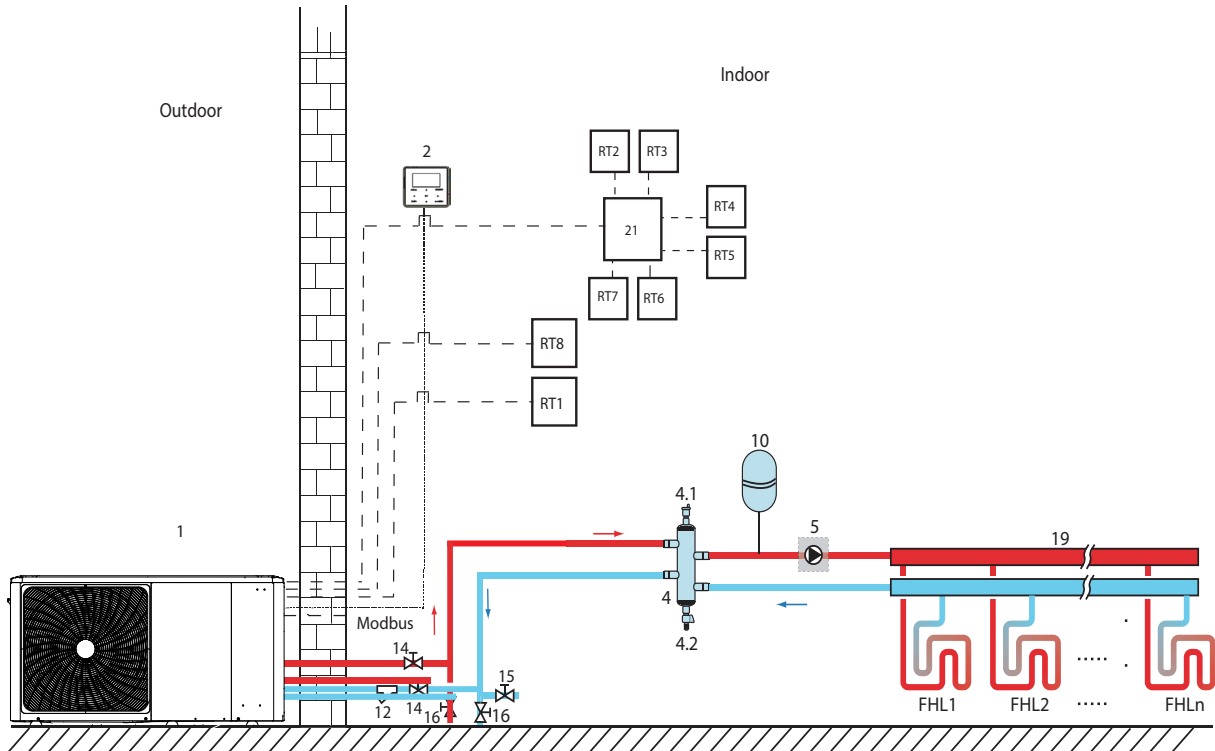

Code	Assembly unit
1	Main unit
2	User interface
4	Balancing tank (field power supply)
4.1	Automatic air purge valve
4.2	Drain valve
5	P_o: External circulation pump (field power supply)
10	Expansion tank (field power supply)
12	Filter (accessory)
14	Shut-off valve (field power supply)
15	Filler valve (field power supply)
16	Discharge valve (field power supply)
19	Manifold/distributor (field power supply)
21	Thermostat transfer board (optional)
RT 1...7	Low voltage room thermostat (field power supply)
RT8	High voltage room thermostat (field power supply)
FHL 1... n	Floor heating circuit (field power supply)

Typical applications

Application 3 - Mode setting control

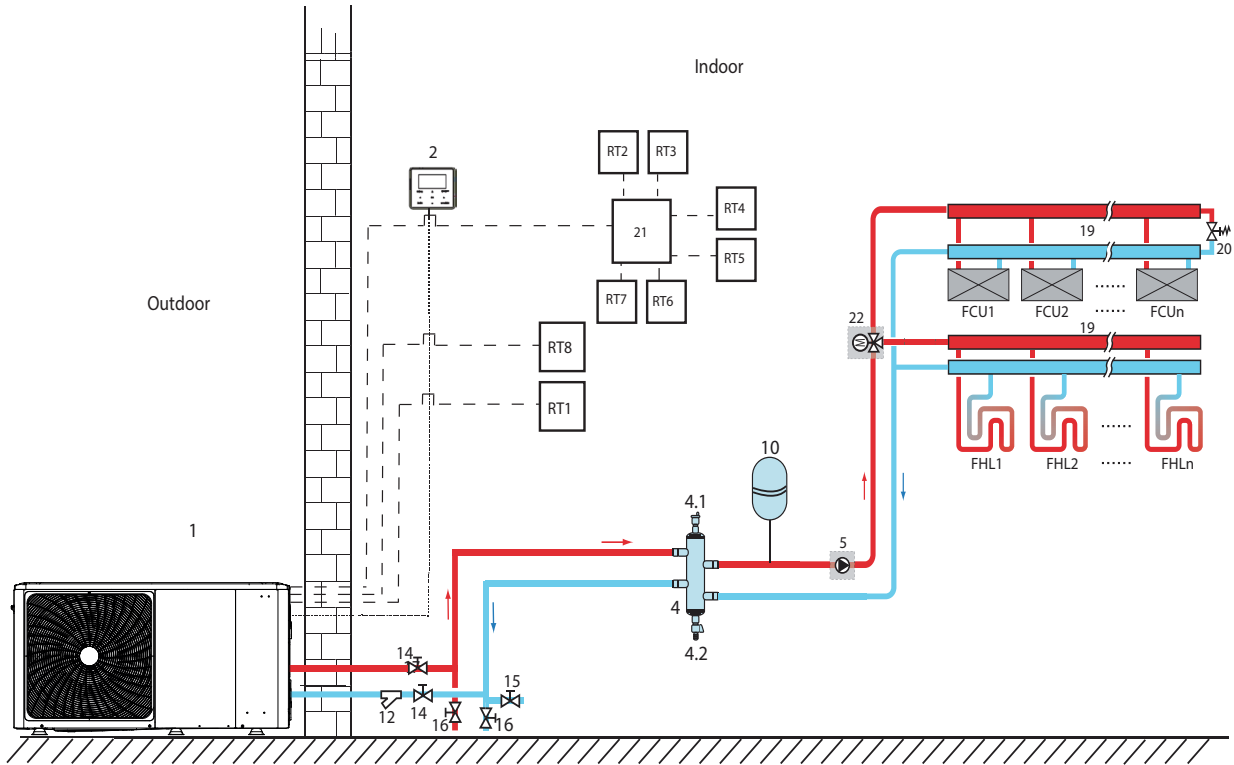

Code	Assembly unit
1	Main unit
2	User interface
4	Balancing tank (field power supply)
4.1	Automatic air purge valve
4.2	Drain valve
5	P_o: External circulation pump (field power supply)
10	Expansion tank (field power supply)
12	Filter (accessory)
14	Shut-off valve (field power supply)
16	Discharge valve (field power supply)
19	Manifold/distributor (field power supply)
20	Bypass valve (field power supply)
21	Thermostat transfer board (optional)
22	SV2: 3-way valve (field power supply)
RT	Low voltage room thermostat
RT8	High voltage room thermostat (field power supply)
FHL	Floor heating circuit
1... n	(field power supply)
FCU	Fan coil (field power supply)
1... n	

Typical applications

Application 4 - Dual zone control

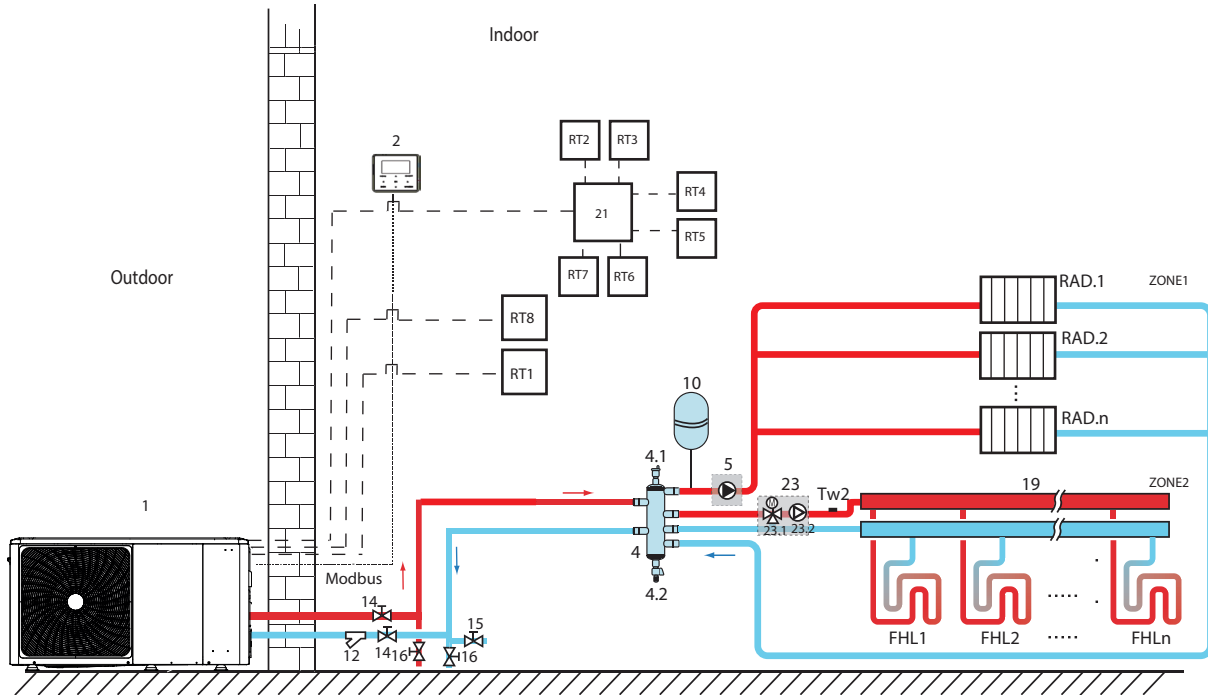

Code	Assembly unit
1	Main unit
2	User interface
4	Balancing tank (field power supply)
4.1	Automatic air purge valve
4.2	Drain valve
5	P_o: External circulation pump (field power supply)
10	Expansion tank (field power supply)
12	Filter (accessory)
14	Shut-off valve (field power supply)
15	Filler valve (field power supply)
16	Discharge valve (field power supply)
19	Manifold/distributor (field power supply)
21	Thermostat transfer board (optional)
23	Mixing station (field power supply)
23.1	SV3: Mixer valve (field power supply)
23.2	P_c: Zone 2 circulation pump (field power supply)
RT 1...7	Low voltage room thermostat (field power supply)
RT8	High voltage room thermostat (field power supply)
Tw2	Zone 2 water flow temperature sensor (optional)
FHL	Floor heating circuit
1... n	(field power supply)
RAD.	Radiator (field power supply)
1... n	

Typical applications

Application 5 - Parallel system

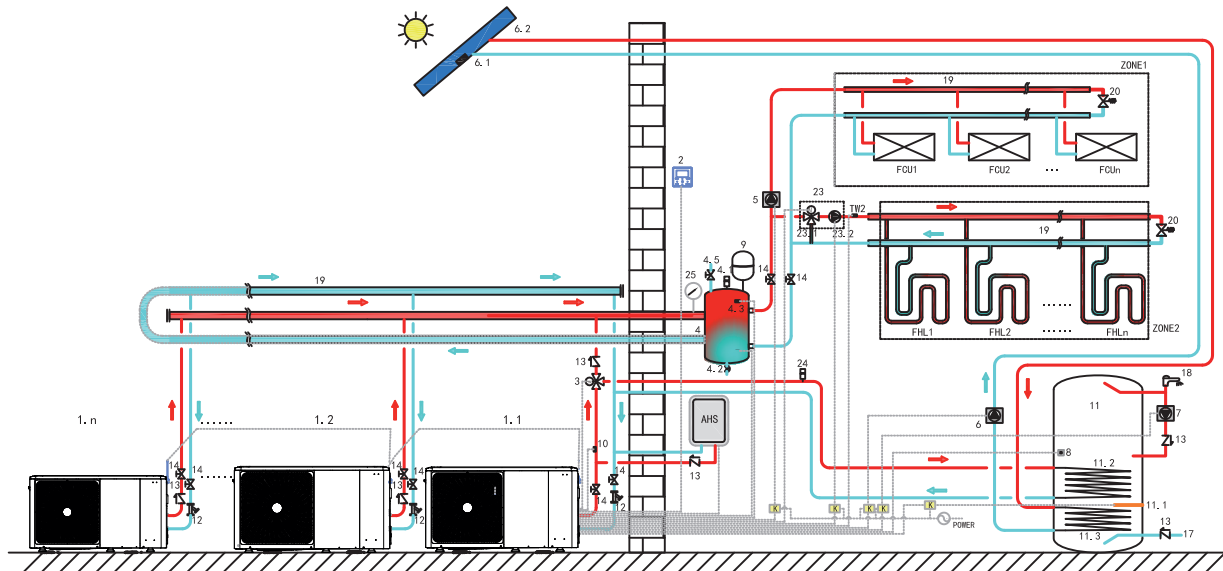

Code	Assembly unit
1.1	Master unit
1.2... n	Slave unit
2	User interface
3	Sv1: 3-way valve (field power supply)
4	Balancing tank (field power supply)
4.1	Automatic air purge valve
4.2	Drain valve
4.3	Tbt1: Upper temperature sensor of the balancing tank (optional)
4.5	Tbt2: Lower temperature sensor of the balancing tank (optional)
5	P_o: External circulation pump (field power supply)
6	P_s: Solar pump (field power supply)
6.1	T solar: Solar temperature sensor (optional)
6.2	Solar panel (field power supply)
7	P_D: Pump for DHW pipes (field power supply)
8	T5: DHW tank temperature sensor (accessory)
9	Expansion tank (field power supply)
10	T1: Total water flow temperature sensor (optional)
11	DHW tank (field power supply)
11.1	TBH: DHW storage tank heater
11.2	Coil 1, heat exchanger for heat pump
11.3	Coil 2, heat exchanger for solar energy
12	Filter (accessory)
13	Control valve (field power supply)

14	Shut-off valve (field power supply)
17	Tap water inlet pipe (field power supply)
18	Hot water tap (field power supply)
19	Manifold/distributor (field power supply)
20	Bypass valve (field power supply)
23	Mixing station (field power supply)
23.1	SV3: Mixer valve (field power supply)
23.2	P_C: Zone 2 circulation pump (field power supply)
24	Automatic air purge valve (field power supply)
25	Water pressure gauge (field power supply)
TW2	Temperature sensor on zone 2 water delivery (optional)
FCU1... n	Fan coil (field power supply)
FHL1... n	Floor heating circuit (field power supply)
K	Meter (field power supply)
ZONE1	The space works in cooling or heating mode
ZONE2	The room works in heating mode only
AHS	Auxiliary heat source (field power supply)



RIELLO S.p.A.
Via Ing. Pilade Riello, 7
37045 Legnago (VR) – Italy
tel. +39 0442 630111

www.berettaheating.com

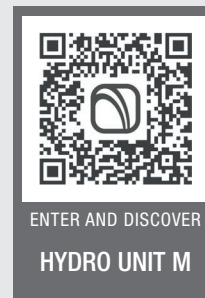

Beretta reserves the right to change the information and specifications contained herein at any time and without notice. The contents and information contained herein are for informational purposes only and are not intended to provide legal or professional advice. Therefore, this document cannot be considered binding towards third parties.

© Riello S.p.A. All rights reserved